



BOOMTRUCKS 40-50 TON LIFTING CAPACITY





40105 SIDE VIEW DIAGRAM

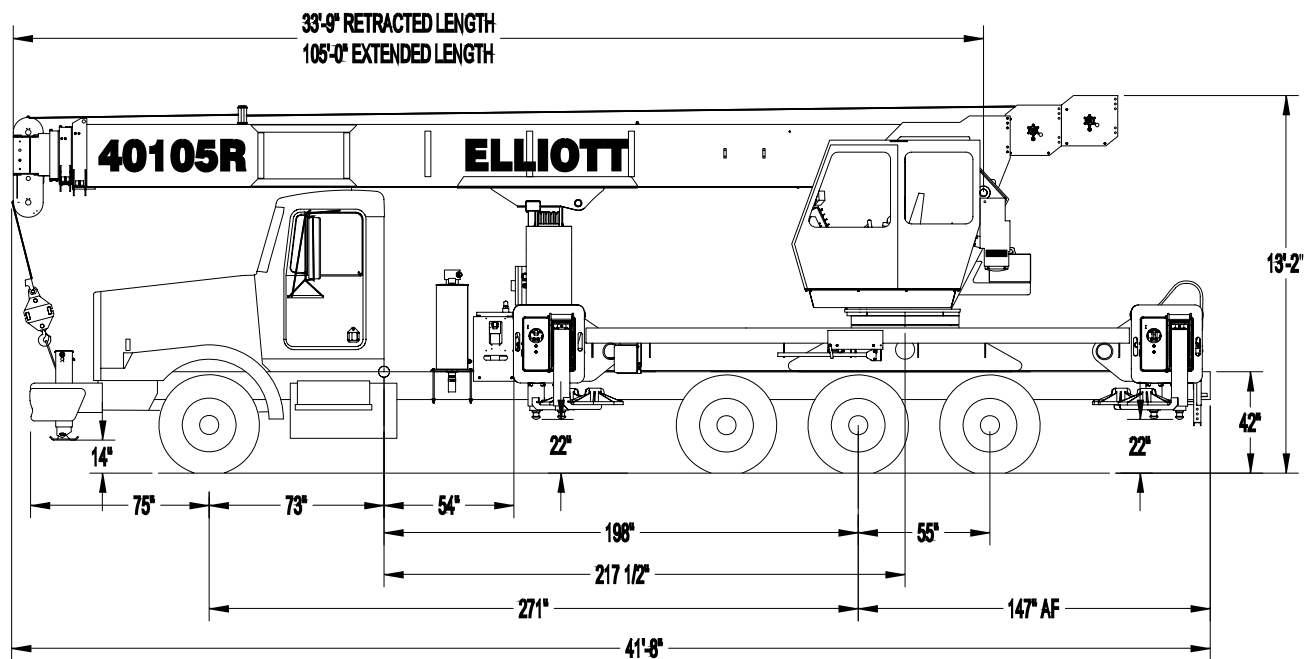

- | | | | |
|----------------------------------|-------------------------------|---------------------------------|--------------------------|
| • Maximum Vertical Reach | 170'/51,8 m | • Powered Boom Sections | 4 |
| • Working Area | 360 Degrees | • Overall Height | 13'2"/4 m |
| • Lifting Capacity | 80,000 lbs/36 287 kg | • Operator Controls | Rotating Seated With Cab |
| • Boom Length | 105'/32 m | • Outrigger Type Front | Out-Down |
| • Crane Weight (Standard) | 38,200 lbs/17 327 kg | • Outrigger Spread Front | 21'2"/6,4 m |
| • Jib Lengths | 32', 31-55'/9,8 m, 9,4-16,8 m | • Outrigger Type Rear | Out-Down |
| • Winch Bare Drum Pull | 15,000 lbs/6804 kg | • Outrigger Spread Rear | 26'2"/8 m |

TECHNICAL SPECIFICATIONS

Crane Capacity: 80,000 lbs at 9' load radius.

Maximum Tip Height: 115' height (170' with optional 31-55' jib)

Control Console: Rotating seated controls with operator cab and deluxe operators seat. Station equipped with four pilot operated control levers for the main crane controls. Operator station includes LMI display, diesel heater, bubble level gauge, engine start/stop switch, signal horn button, variable speed throttle switch, lifting capacity chart, range diagram chart, boom angle indicator, system pressure gauge, 12V DC power source, and cup holder. Independent ground level electric operated outrigger controls.

Boom: Four-section fully proportional, high strength steel plated rectangular tube sections. A maximum boom tip height of 170' mounted on a truck. The boom nose contains one floating upper sheave and three lower sheaves. Assembly includes heavy-duty cylinder fittings, pivot pins, and replaceable wear pads.

Winch: Mounted at the base of the boom for a long fleet angle and flat level spooling of cable. Winch is driven by a planetary reducer and powered by a hydraulic motor. Burst-of-speed winch provides increased line speed. The winch brake is spring applied, pressure release design. Supplied with 430' of 5/8" diameter rotation resistant wire rope with a single line pull of 10,000 pounds, and a downhaul ball with swivel hook for single part line.

Load Moment Indicator System: System senses hoist cylinder pressures, boom length and boom angle with hydraulic function lockout. The display console is equipped with a bar graph showing crane utilization, boom angle or boom length, a mode select controls for main boom and jib operation, and an anti-two block with an audio/visual warning and shut-off functions to limit

Elliott Equipment Company reserves the right to change the specification of any unit at any time without prior notice. This brochure is only a statement of general specifications on the date of this publication. For more detailed info on specific Elliott trucks go to www.elliottequip.com

hook-boom point contact.

Outriggers: Two sets of out and down overframe outriggers with 21'2" span behind cab, and 26'2" span in rear. Outriggers are configured for full span, mid span, and full retracted operation. Outriggers equipped with 22" diameter ball socket aluminum removable pads that stow on vertical outrigger legs. Front stabilizer bumper is required.

Frame: Full length, all welded rigid 4-plate design sub-frame. Sub-frame allows for bolt-on addition of aluminum bed wings, with top plate of subbase serving as a portion of the bed deck, to form a three-piece bed.

Turret: Reverse offset turret is one-piece weldment. Turret rotates on large diameter ball bearing.

Rotation: Hydraulic motor drives turret through double reduction planetary swing drive for 360 degree continuous rotation. Glide-swing drive system has manual foot applied brake

Lift: One double-acting long stroke cylinder provides smooth and stable boom elevation. Holding valve prevents boom from falling in event of hose failure.

Boom Extension: Incorporates a 2-stage hydraulic extension cylinder, attached to the largest boom section, with a proportional cable extension system driving the outermost sections.

Hoses: All high pressure hoses are wire braid reinforced with a minimum safety factor of 4 to 1.

Cylinders: All cylinders use microhoned cylinder tubing, chrome shafts, top grade packing and protective rod wipers. Cylinder-mounted holding valves provided on all load-holding cylinders.

Hydraulic System: Equipped with air-shift PTO, piston pump, SAE O-ring face seals on pressure lines, and a 10-micron return line filter. The control valve distributes all flow to hoist system,

swing circuit, and other crane functions. System is closed center type.

Oil Tank Capacity: 143 gallon mounted on top of truck frame.

Cab Equipment: Air shift PTO with indicator lights installed in truck cab. U/L approved 5:BC dry chemical fire extinguisher installed in truck cab.

Operators Manual & Video: Two CD copies and one hard copy of operation, maintenance, safety and parts manual provided with each unit. Operational and safety video provided at delivery.

Installation: Unit installed on chassis, painted, system and tank filled with oil, tested, inspected, and ready to operate.

Standard Paint: Paint turret and boom white, outriggers red, and bed and boxes black.

Bumper: Bureau of Motor Carrier Safety rear bumper.

Weight: Approximately 38,200 lbs. with 18' aluminum bed less truck.

Truck Chassis Required: Approx. 198" C.T., RBM 3,300,000 in-lb. per rail, 20,000 lb. front axle and 78,000 lb. GVWR required. Trucks must have front frame extension, 12V electrical system with high capacity alternator, cab clearance stop/tail/backup lights, and I.D. lamps. Recommended GVWR is minimum for BoomTruck with flatbed only. Contact factory when additional equipment is to be added.

Options:

Air Conditioning for Crane Cab.

31-55 Ft. Telescopic Jib.

Gravity Leveled Work Platform.

Swing Counterweight up to 1,600 lbs.

Radio Remote Controls.

Auxiliary Winch for Faster Jib Deployment.

Much More...

LOAD CHART - MAIN BOOM, FULL-SPAN OUTRIGGERS



MODEL H4000

105-ft BOOM

MAIN BOOM LOAD RATINGS WITH FULLY EXTENDED OUTRIGGERS

MAIN BOOM LOAD RATINGS

LOAD RATINGS IN lbs WITH OUTRIGGERS AND STABILIZERS EXTENDED

LOAD RADIUS IN FEET	LOADED BOOM ANGLE	33-ft	A	LOADED BOOM ANGLE	B	LOADED BOOM ANGLE	C	LOADED BOOM ANGLE	D	LOADED BOOM ANGLE	E	LOADED BOOM ANGLE	F	
		33-ft	46-ft		57-ft		69-ft		81-ft		93-ft		105-ft	
9	72.6	80,000												
10	70.4	64,500	76.5	46,600										
12	66.4	58,100	73.9	46,600	77.9	46,600								
15	60.1	50,800	69.9	46,600	74.9	44,600	78.4	41,700						
20	48.5	39,700	62.7	38,900	69.3	36,500	74.0	34,900	77.2	30,700				
25	33.4	30,000	54.8	31,000	63.5	31,100	69.5	29,500	73.4	26,100	76.4	23,500	78.4	19,000
30			45.7	24,600	57.2	25,200	64.7	25,500	69.5	22,600	73.1	20,400	75.9	18,700
35			34.8	18,900	50.3	19,350	59.5	19,700	65.5	19,700	69.7	17,800	72.9	16,300
40			17.9	14,900	42.5	15,300	53.9	15,600	61.1	15,900	66.2	15,700	69.9	14,500
45					33.3	12,400	48.0	12,700	56.5	13,000	62.4	13,200	66.9	13,500
50					20.1	10,100	41.5	10,500	51.7	10,750	58.4	10,900	63.5	11,150
55							34.6	8,800	47.0	9,050	54.7	9,200	60.4	9,350
60							25.0	7,200	41.4	7,600	50.5	7,800	56.8	7,950
65									34.9	6,400	45.9	6,600	53.1	6,750
70									27.1	5,450	40.9	5,600	49.2	5,750
75									15.3	4,500	35.2	4,700	45.1	4,800
80											28.6	3,950	40.6	4,100
85											19.7	3,300	35.7	3,450
90													30.0	2,850
95													22.8	2,350
100													11.0	1,800
	0	18,500	0	11,900	0	8,150	0	5,450	0	3,900	0	2,500	0	1,000
DEDUCTIONS FOR STOWED JIB (lbs)		1,000		750		600		500		400		350		300

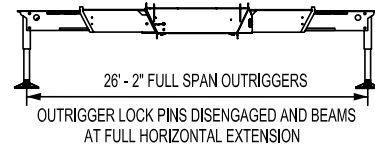

ELLIOTT EQUIPMENT CO. SUPPLIED
 LOADLINE EQUIPMENT DEDUCTIONS:
 DOWNHAUL WEIGHT225 lbs
 ONE SHEAVE BLOCK.....424 lbs
 TWO SHEAVE BLOCK.....592 lbs
 THREE SHEAVE BLOCK.....639 lbs
 FOUR SHEAVE BLOCK.....762 lbs
 AUXILIARY SHEAVE.....100 lbs

DEDUCTIONS FOR STOWED EXTENDABLE JIB (lbs)

CRANE MEETS ASME B30.5 REQUIREMENTS AT TIME OF MANUFACTURE

DO NOT PAINT OVER ANY LABELS 1115620 090407



Elliott Equipment Company
 4427 South 76th Circle
 Omaha, NE 68127
 Phone: 402-592-4500
 Fax: 402-592-4553
 Email: sales@elliottequip.com

Built for You.
 www.elliottequip.com

LOAD CHART - MAIN BOOM, MID-SPAN OUTRIGGERS



MODEL H4000

105-ft BOOM

MAIN BOOM LOAD RATINGS WITH MIDSPAN OUTRIGGERS

LOAD RATINGS IN lbs WITH OUTRIGGERS AND STABILIZERS EXTENDED

LOAD RADIUS IN FEET	LOADED BOOM ANGLE	33-ft	LOADED BOOM ANGLE	A 46-ft	LOADED BOOM ANGLE	B 57-ft	LOADED BOOM ANGLE	C 69-ft	LOADED BOOM ANGLE	D 81-ft	LOADED BOOM ANGLE	E 93-ft	LOADED BOOM ANGLE	F 105-ft
9	71.3	80,000												
10	69.1	64,500	75.5	46,600										
12	65.2	58,100	72.9	46,600	77.1	46,600								
15	59.1	50,800	69.0	46,600	74.1	44,600	77.8	41,700						
20	47.7	29,600	61.7	33,300	68.4	34,000	73.4	34,900	76.6	30,700				
25	34.1	17,400	53.6	19,500	62.2	20,300	68.1	20,800	72.4	21,400	75.7	22,000	78.2	20,000
30			44.9	13,000	55.8	13,450	63.1	13,900	68.1	14,400	71.8	14,800	74.8	15,200
35			35.8	9,000	49.8	9,450	58.4	9,800	63.8	10,200	68.0	10,550	71.4	10,800
40			22.3	6,300	42.5	6,750	53.1	7,100	59.8	7,400	64.7	7,700	68.5	8,000
45					33.9	4,850	47.4	5,100	55.4	5,450	60.9	5,700	65.2	5,950
50					22.9	3,400	41.2	3,650	50.7	3,950	57.1	4,200	61.9	4,400
55							34.0	2,600	45.7	2,850	53.1	3,100	58.5	3,300
60							25.2	1,700	40.3	1,950	48.9	2,150	55.0	2,300
65									34.2	1,200	44.4	1,400	51.4	1,500
	0	9,800	0	4,850	0	2,400	0	800						
DEDUCTIONS FOR STOWED JIB (lbs)		1,000		750		600		500		400		350		300

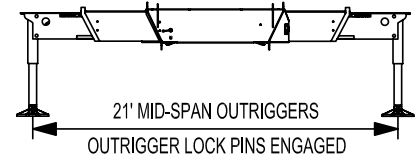

ELLIOTT EQUIPMENT CO. SUPPLIED
LOADLINE EQUIPMENT DEDUCTIONS:
DOWNHAUL WEIGHT225 lbs
ONE SHEAVE BLOCK.....424 lbs
TWO SHEAVE BLOCK.....592 lbs
THREE SHEAVE BLOCK.....639 lbs
FOUR SHEAVE BLOCK.....762 lbs
AUXILIARY SHEAVE.....100 lbs

DEDUCTIONS FOR STOWED EXTENDABLE JIB (lbs)

NOTE:

- Operate jib by radius when main boom is fully extended. Increase boom angle if necessary to maintain load radius.
- When boom is retracted, operate jib by boom angles. Do not exceed any rated jib capacities at reduced boom lengths.
- Capacities do not exceed stability based on ISO 4305-1991.
- Load ratings above bold line are structurally limited.
- Personnel handling is allowed only with full span outriggers.
- Boom load ratings are based on loaded boom radius. Loaded boom angles are given as reference only.

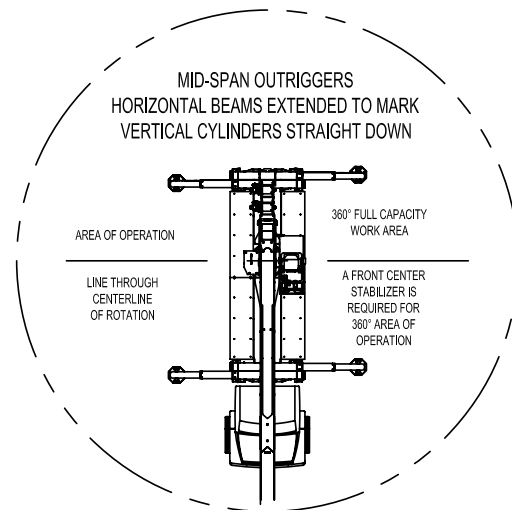

CRANE MEETS ASME B30.5 REQUIREMENTS AT TIME OF MANUFACTURE

DO NOT PAINT OVER ANY LABELS

1115620 090407

LOAD CHART - MAIN BOOM, RETRACTED OUTRIGGERS



MODEL H4000 105-ft BOOM

MAIN BOOM LOAD RATINGS WITH OUTRIGGERS AT RETRACTED POSITION

RANGE DIAGRAM WITH OUTRIGGERS IN RETRACTED POSITION

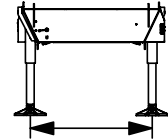
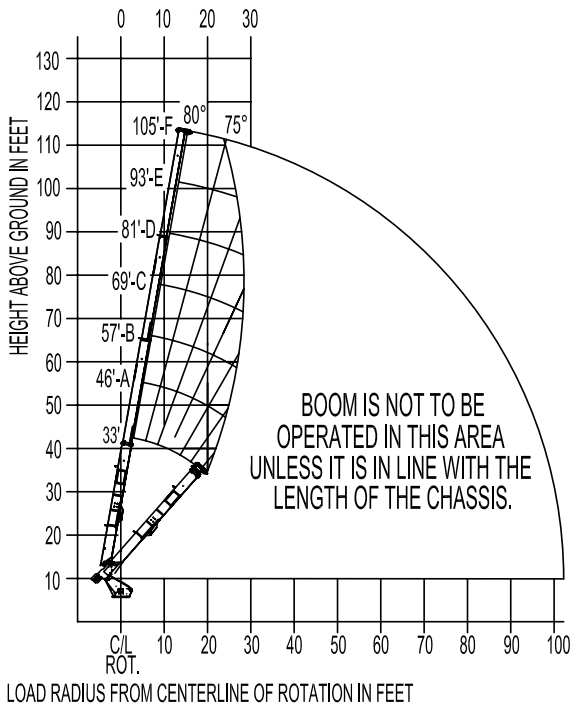

7' RETRACTED OUTRIGGERS
OUTRIGGER LOCK PINS DISENGAGED AND BEAMS
AT FULL HORIZONTAL RETRACT

- ELLIOTT EQUIPMENT CO. SUPPLIED
LOADLINE EQUIPMENT DEDUCTIONS:
- DOWNHAUL WEIGHT225 lbs
 - ONE SHEAVE BLOCK.....424 lbs
 - TWO SHEAVE BLOCK.....592 lbs
 - THREE SHEAVE BLOCK.....639 lbs
 - FOUR SHEAVE BLOCK.....762 lbs
 - AUXILIARY SHEAVE.....100 lbs

MAIN BOOM LOAD RATINGS WITH NO SPAN OUTRIGGERS

LOAD RATINGS IN lbs WITH OUTRIGGERS RETRACTED AND STABILIZERS EXTENDED

LOAD RADIUS IN FEET	LOADED BOOM ANGLE	33-ft	LOADED BOOM ANGLE	A	LOADED BOOM ANGLE	B	LOADED BOOM ANGLE	C	LOADED BOOM ANGLE	D	LOADED BOOM ANGLE	E	LOADED BOOM ANGLE	F
9	70.2	18,800												
10	68.2	15,000	74.6	16,600										
12	64.3	10,350	71.8	11,500	75.7	11,900								
15	59.3	6,050	68.3	6,900	72.9	7,150	76.2	7,400						
20	48.6	2,250	61.2	2,950	67.3	3,150	71.6	3,300	74.6	3,500				
25			53.7	850	61.5	1,000	67.0	1,150	70.7	1,300	73.5	1,400	75.7	1,500

DEDUCTIONS FOR STOWED JIB (lbs)	1,000	750	600	500	400	350	300

CRANE MEETS ASME B30.5 REQUIREMENTS AT TIME OF MANUFACTURE

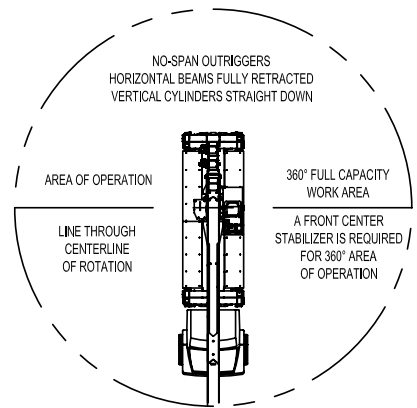

DEDUCTIONS FOR STOWED EXTENDABLE JIB (lbs)

DO NOT PAINT OVER ANY LABELS 1115620 090407

RANGE CHART - MAIN BOOM, FULL-SPAN OUTRIGGERS



MODEL H4000

105-ft BOOM

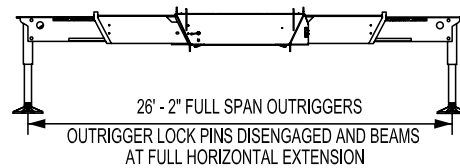
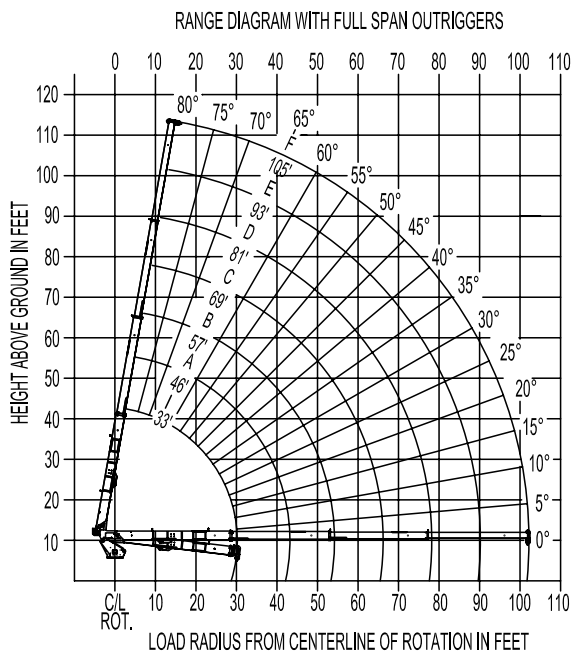

NOTE:

1. Operate jib by radius when main boom is fully extended. Increase boom angle if necessary to maintain load radius.
2. When boom is retracted, operate jib by boom angles. Do not exceed any rated jib capacities at reduced boom lengths.
3. Capacities do not exceed 85% stability.
4. Load ratings above bold line are structurally limited.
5. Personnel handling is allowed only with full span outriggers.
6. Boom load ratings are based on loaded boom radius. Loaded boom angles are given as reference only.

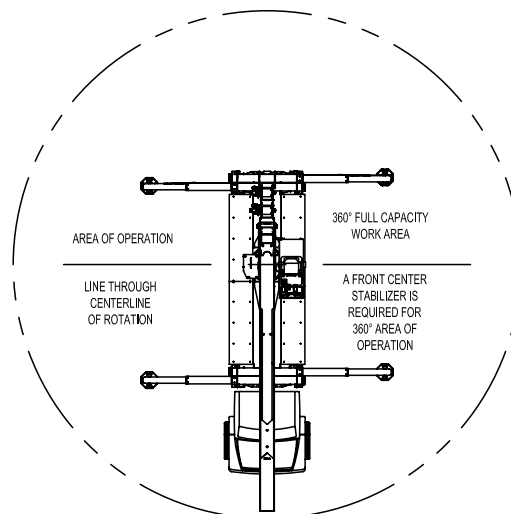

CRANE MEETS ASME B30.5 REQUIREMENTS AT TIME OF MANUFACTURE

DO NOT PAINT OVER ANY LABELS 1115620 090407



Elliott Equipment Company Phone: 402-592-4500
4427 South 76th Circle Fax: 402-592-4553
Omaha, NE 68127 Email: sales@elliottequip.com

Built for You.
www.elliottequip.com

RANGE CHART - MAIN BOOM, MID-SPAN OUTRIGGERS



MODEL H4000

105-ft BOOM

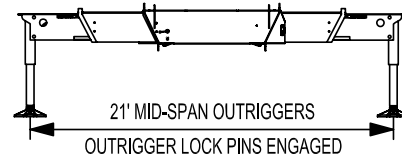

RANGE DIAGRAM WITH OUTRIGGERS IN MID-SPAN POSITION

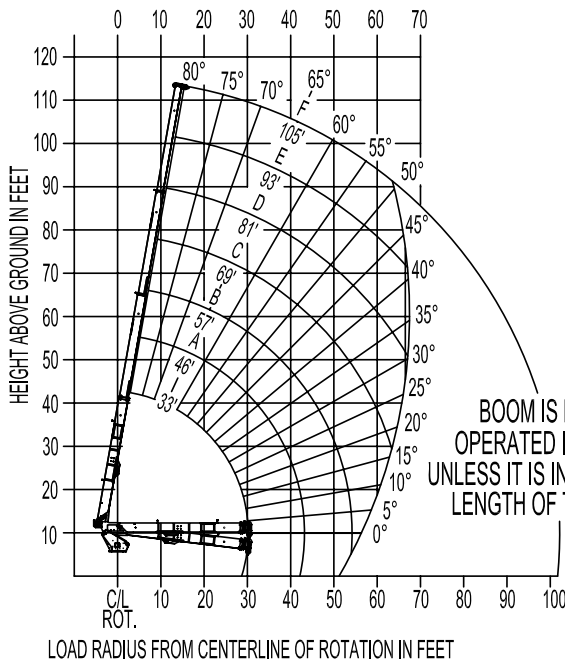

NOTE:

1. Operate jib by radius when main boom is fully extended. Increase boom angle if necessary to maintain load radius.
2. When boom is retracted, operate jib by boom angles. Do not exceed any rated jib capacities at reduced boom lengths.
3. Capacities do not exceed stability based on ISO 4305-1991.
4. Load ratings above bold line are structurally limited.
5. Personnel handling is allowed only with full span outriggers.
6. Boom load ratings are based on loaded boom radius. Loaded boom angles are given as reference only.

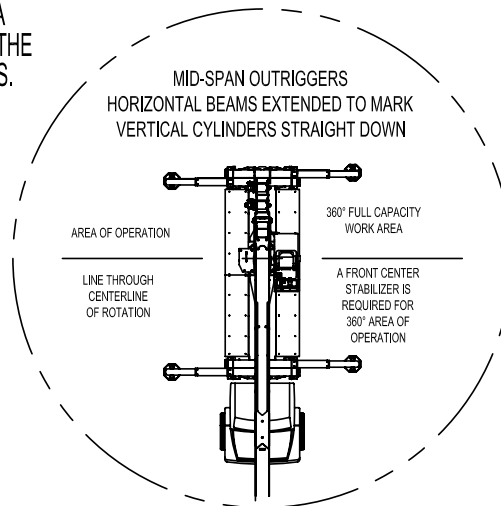

CRANE MEETS ASME B30.5 REQUIREMENTS AT TIME OF MANUFACTURE

DO NOT PAINT OVER ANY LABELS

1115620 090407

MAIN BOOM WINCH DATA



MODEL H4000

105-ft BOOM

PARTS OF LINE

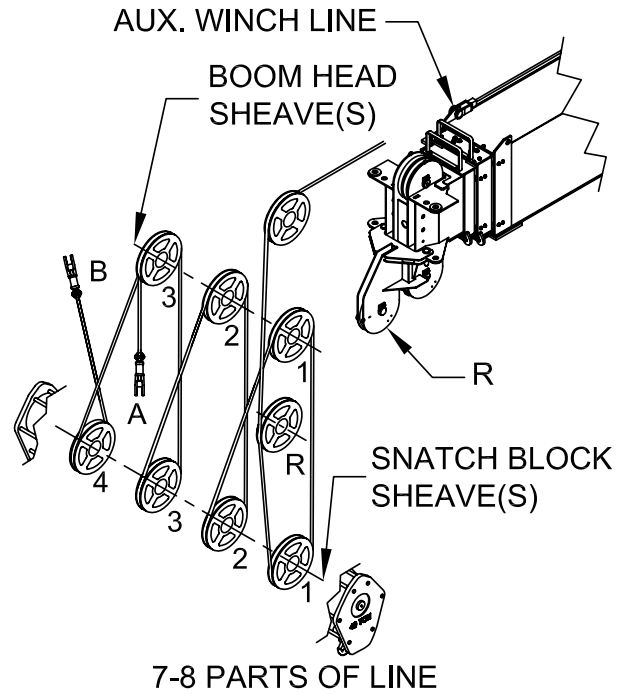
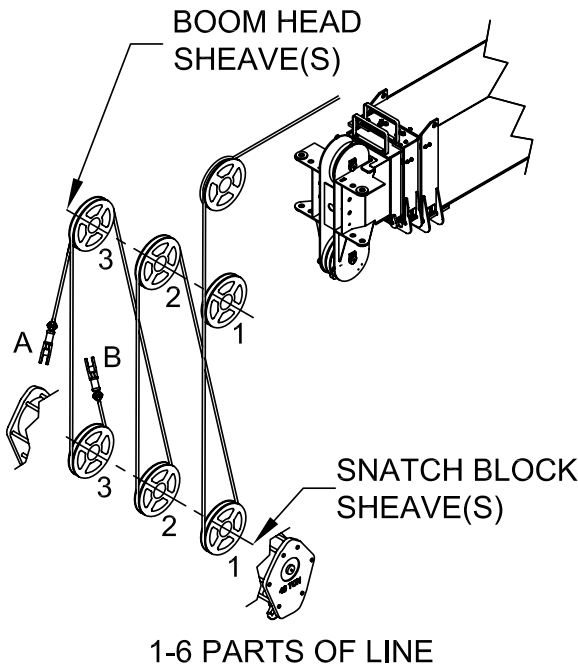

NOTICE:

- DO NOT DEADHEAD LINE BLOCK AGAINST BOOM TIP WHEN EXTENDING BOOM.
- KEEP AT LEAST 5 WRAPS OF LOADLINE ON THE WINCH DRUM AT ALL TIMES.
- USE ONLY 5/8" DIAMETER WIRE ROPE, AS SPECIFIED, WITH THE PROPER BREAKING STRENGTH LISTED.
- ANTI-TWO-BLOCK SYSTEM MUST BE IN GOOD OPERATING CONDITION BEFORE OPERATING CRANE. SEE OPERATION & SAFETY MANUAL.

PARTS OF LINE	SHEAVE(S) ON BOOM HEAD	SHEAVE(S) ON SNATCH BLOCK	5/8" - SPIN RESISTANT (5:1 S.F.) 50,000-lbs. BREAKING STRENGTH
1	1	A	10,000 lbs
2	1B	1	20,000 lbs
3	12	1A	30,000 lbs
4	12B	12	40,000 lbs
5	123	12A	50,000 lbs
6	123B	123	60,000 lbs
7	R123	123A	70,000 lbs
8	R123B	1234	80,000 lbs

A-DEAD END FOR ODD PARTS OF LINE
 B-DEAD END FOR EVEN PARTS OF LINE
 R-ROOSTER SHEAVE REQUIRED WHEN USING 7 AND 8 PARTS OF LINE

CRANE MEETS ASME B30.5 REQUIREMENTS AT TIME OF MANUFACTURE

DO NOT PAINT OVER ANY LABELS

1115620 090407



Elliott Equipment Company
 4427 South 76th Circle
 Omaha, NE 68127
 Phone: 402-592-4500
 Fax: 402-592-4553
 Email: sales@elliottequip.com

Built for You.
www.elliottequip.com

TRUCK CHASSIS SPECIFICATIONS

	40105 BoomTruck
Wheelbase (WB)	288" / 731 cm
Cab to Tandem (CT)	198" / 503 cm
Cab to End of Frame (EOF)	345" / 876 cm
Frame Section Modulus	30.0 in3-110,000 psi / 758,428 kPa
Front Axle Gross Weight Rating	20,000 lb / 9072 kg
Rear Axle Gross Weight Rating	58,000 lb / 26 308 kg
Integral Front Frame Rails	Required for Front Stabilizer

Chassis data is minimum general requirements-not for engineering.
 Actual dimensions and truck data will depend on truck selection and axle configuration.
 *Minimum chassis weight is required to meet 85% stbilty requirements.

OPTIONS



Radio Remote Control

Interference protected radio remotes let you get closer to your work and have full control over your machine. Includes battery charging feature and optional LMI screen.

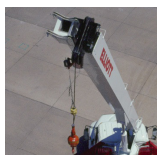

Pin-On Jib Attachments

One piece & two piece telescoping or fixed jibs that stow on the side of the boom for easy placement while on the worksite.



Air Conditioning in Crane Cab

Work all day in comfort with an high efficiency air conditioning system mounted on the rear of the crane control cab.



Auxiliary Winch System

Take advantage of the auxiliary winch to quickly deploy Elliott's telescopic jib or perform wireline work applications.



Tool Boxes

Optional tool boxes and bed storage can accommodate any storage need for tools, work materials and more.

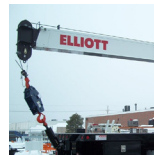

Hook Block for Multi-Part Line

Elliott can include a hook block device for up to 8 parts of line to improve lifting capabilities and allow you to maximize your use of the crane.



Gravity Levelled Work Platform

Elliott's new 2-man platform features a hydraulic yoke lifting system for easy attachment to the boom tip. Fully OSHA compliant and heavy duty.



Body Mounted Hose Reels and Circuits

Let us work with you to customize your tool compatability by adding hose reels or hydraulic circuits to the crane bed.

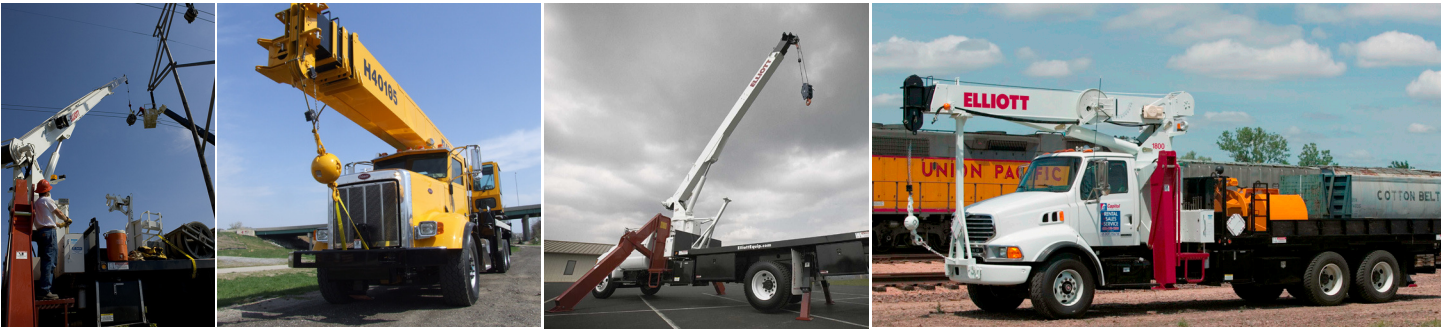

40142 SIDE VIEW DIAGRAM

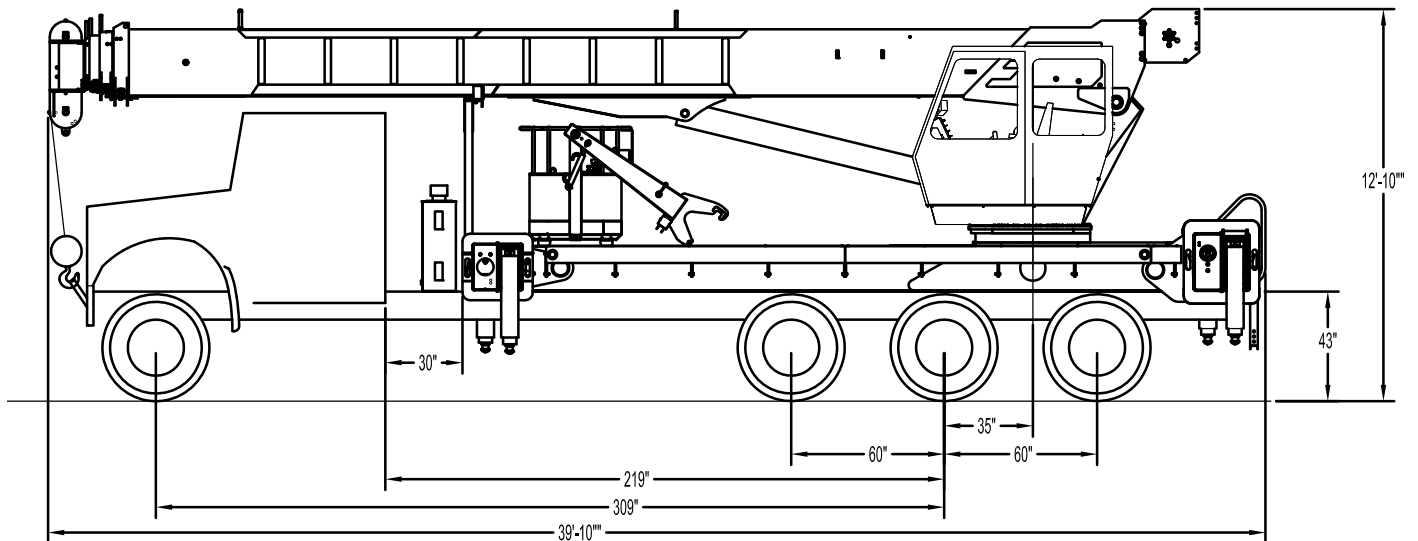

- | | | | |
|----------------------------------|-------------------------------|---------------------------------|--------------------------------|
| • Maximum Vertical Reach | 207'63,1 m | • Powered Boom Sections | 5 |
| • Working Area | 360 Degrees | • Overall Height | 12'10"/3,9 m |
| • Lifting Capacity | 80,000 lbs/36 287 kg | • Operator Controls | Rotating Cab with Control Seat |
| • Boom Length | 142'43,3 m | • Outrigger Type Front | Out-Down |
| • Crane Weight (Standard) | 40,300 lbs/18 280 kg | • Outrigger Spread Front | 21'2"/6,4 m |
| • Jib Lengths | 26', 32'-55'/ 8 m, 9,7-16,8 m | • Outrigger Type Rear | Out-Down |
| • Winch Bare Drum Pull | 15,000 lbs/6804 kg | • Outrigger Spread Rear | 26'2"/8 m |

TECHNICAL SPECIFICATIONS

Crane Capacity: 80,000 lbs at 7' load radius.

Maximum Tip Height: 142' height (207' with optional 32'-55' jib)

Control Console: Rotating seated controls with operator cab and deluxe operators seat. Station equipped with four pilot operated control levers for the main crane controls. Operator station includes LMI display, diesel heater, bubble level gauge, engine start/stop switch, signal horn button, variable speed throttle switch, lifting capacity chart, range diagram chart, boom angle indicator, system pressure gauge, 12V DC power source, and cup holder. Independent ground level electric operated outrigger controls.

Boom: Five-section fully proportional, high strength steel plated rectangular tube sections. 34'9" retracted and 142' extended boom. A maximum boom tip height of 152' mounted on a truck. The boom nose contains one floating upper sheave and three lower sheaves. Assembly includes heavy-duty cylinder fittings, pivot pins, and replaceable wear pads.

Winch: Mounted at the base of the boom for a long fleet angle and flat level spooling of cable. Winch is driven by a planetary reducer and powered by a hydraulic motor. Burst-of-speed winch provides increased line speed. The winch brake is spring applied, pressure release design. Supplied with 430' of 5/8" diameter rotation resistant wire rope with a single line pull of 10,000 lbs., and a downhill ball with swivel hook for single part line.

Load Moment Indicator System: System senses hoist cylinder pressures, boom length and boom angle with hydraulic function lockout. The display console is equipped with a bar graph showing crane utilization, boom angle or boom length, a mode select controls for main boom and jib operation, and an anti-two block with an audio/visual

Elliott Equipment Company reserves the right to change the specification of any unit at any time without prior notice. This brochure is only a statement of general specifications on the date of this publication. For more detailed info on specific Elliott trucks go to www.elliottequip.com

warning and shut-off functions to limit hook-boom point contact. Internal boom anti-two-block.

Outriggers: Two sets of out and down overframe outriggers with 21'2" span in front and 26'2" span at rear. Outriggers are configured for full span or mid-span only. Outriggers equipped with 22" diameter ball socket aluminum removable pads that stow on vertical outrigger legs. Front bumper stabilizer may be required.

Frame: Full length, all welded rigid 4-plate design sub-frame. Sub-frame allows for bolt-on addition of aluminum bed wings, with top plate of subbase serving as a portion of the bed deck, to form a three-piece bed.

Turret: Reverse offset turret is one-piece weldment. Turret rotates on large diameter ball bearing.

Rotation: Hydraulic motor drives turret through double reduction planetary swing drive for 360 degree continuous rotation. Glide-swing drive system has manual foot applied brake

Lift: One double-acting long stroke cylinder provides smooth and stable boom elevation. Holding valve prevents boom from falling in event of hose failure.

Boom Extension: Incorporates a 2-stage hydraulic extension cylinder, attached to the largest boom section, with a proportional cable extension system driving the outermost sections.

Hoses: All high pressure hoses are wire braid reinforced with a minimum safety factor of 4 to 1.

Cylinders: All cylinders use microhoned cylinder tubing, chrome shafts, top grade packing and protective rod wipers. Cylinder-mounted holding valves provided on all load-holding cylinders.

Hydraulic System: Equipped with air-shift PTO, piston pump, SAE O-ring face seals on pressure lines, and a

10-micron return line filter. The control valve distributes all flow to hoist system, swing circuit, and other crane functions. System is closed center type. Includes hydraulic oil cooler.

Oil Tank Capacity: 143 gallon mounted to top of frame.

Cab Equipment: Air shift PTO with indicator lights installed in truck cab. U/L approved 5:BC dry chemical fire extinguisher installed in truck cab.

Operators Manual & Video: Two CD copies and one hard copy of operation, maintenance, safety and parts manual provided with each unit. Operational and safety video provided at delivery.

Installation: Unit installed on chassis, painted, system and tank filled with oil, tested, inspected, and ready to operate.

Standard Paint: Paint turret and boom white, outriggers red, and bed and boxes black.

Bumper: Bureau of Motor Carrier Safety rear bumper.

Weight: Approximately 40,300 lbs. with 18' aluminum bed less truck.

Truck Chassis Required: Approx. 219" C.T., RBM 3,300,000 in-lb. per rail, 20,000 lb. front axle and 78,000 lb. GVWR required. Trucks must have 12V electrical system with high capacity alternator, cab clearance stop/tail/backup lights, and I.D. lamps. Additional configurations available for bridge legal cranes and export. Contact factory when additional equipment is to be added.

Options:

Air Conditioning for Crane Cab.

32'-55' 2-Stage Jib.

Gravity Leveled Work Platform.

Wireless Radio Remote Controls.

Auxiliary Winch Package.

Winch Drum Rotation Indicator.

Much More...

LOAD CHART - MAIN BOOM, FULL-SPAN OUTRIGGERS



MODEL 4000 142-ft BOOM

MAIN BOOM LOAD RATINGS WITH FULLY EXTENDED OUTRIGGERS

MAIN BOOM LOAD RATINGS

LOAD RATINGS IN lbs WITH OUTRIGGERS AND STABILIZERS EXTENDED

LOAD RADIUS IN FEET	LOADED BOOM ANGLE	34-ft	LOADED BOOM ANGLE	A 47-ft	LOADED BOOM ANGLE	B 61-ft	LOADED BOOM ANGLE	C 74-ft	LOADED BOOM ANGLE	D 88-ft	LOADED BOOM ANGLE	E 101-ft	LOADED BOOM ANGLE	F 115-ft	LOADED BOOM ANGLE	G 128-ft	LOADED BOOM ANGLE	H 142-ft	
7	75.4	80,000																	
8	73.2	75,000																	
10	71.0	66,500	76.7	43,000															
12	67.3	56,100	74.3	43,000	79.1	43,000													
15	61.7	49,000	70.5	43,000	76.3	42,400	79.5	36,600											
20	50.9	35,500	63.6	34,000	71.4	34,000	75.7	31,700	78.7	24,900									
25	38.1	24,700	56.0	25,000	66.3	28,200	71.5	26,400	75.2	21,000	77.8	17,500							
30	19.3	18,300	47.8	18,800	60.6	23,200	67.2	19,300	71.7	18,400	75.0	16,000	77.5	13,400	79.3	11,500			
35			38.0	14,500	54.5	14,800	62.8	15,000	68.1	15,000	72.0	14,400	75.0	11,800	77.0	10,100	79.1	6,600	
40			25.2	11,500	48.0	11,800	58.0	12,000	64.4	12,000	68.8	12,200	72.2	10,700	74.9	8,900	77.0	6,600	
45					40.7	9,600	52.9	9,800	60.6	9,900	65.6	10,000	69.8	9,400	72.6	8,100	74.8	6,600	
50					31.9	7,800	47.3	8,000	56.5	8,100	62.3	8,200	67.0	8,300	70.1	7,400	72.7	5,900	
55					19.8	6,500	41.2	6,600	52.3	6,700	59.1	6,800	64.2	6,900	67.6	6,500	70.5	5,300	
60							34.9	5,400	48.0	5,500	55.5	5,600	61.2	5,800	65.0	5,800	68.3	4,800	
65							26.4	4,400	43.0	4,500	51.8	4,700	58.1	4,700	62.4	4,800	65.9	4,300	
70							12.9	3,500	37.3	3,650	47.6	3,800	55.0	3,700	59.7	3,800	63.6	3,900	
75									30.8	2,900	43.1	3,000	54.6	3,000	56.9	3,100	61.2	3,200	
80									22.5	2,200	38.2	2,300	47.8	2,400	54.0	2,400	58.7	2,500	
85											32.7	1,750	43.8	1,850	50.8	2,000	56.2	2,000	
90											26.1	1,250	39.6	1,400	47.4	1,500	53.5	1,500	
95											17.1	800	34.9	1,000	43.8	1,100	50.7	1,100	
100													29.6	600	40.0	700	47.6	750	
105															35.8	500	44.3	500	
0		16,000	0	9,550	0	5,600	0	3,300	0	1,650	0	500							
DEDUCTIONS FOR STOWED EXTENDABLE JIB (lbs)		950		700		550		450		400		350		300		250		200	DEDUCTIONS FOR STOWED EXTENDABLE JIB (lbs)

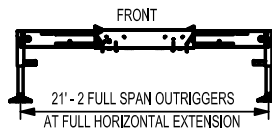
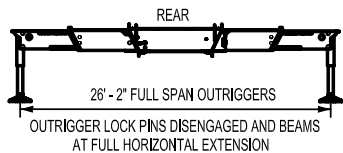

ELLIOTT EQUIPMENT CO. SUPPLIED LOADLINE EQUIPMENT DEDUCTIONS:

- DOWNHAUL WEIGHT.....225 lbs
- ONE SHEAVE BLOCK.....424 lbs
- TWO SHEAVE BLOCK.....592 lbs
- THREE SHEAVE BLOCK.....639 lbs
- FOUR SHEAVE BLOCK.....762 lbs
- AUXILIARY SHEAVE.....100 lbs

CRANE MEETS ASME B30.5 REQUIREMENTS AT TIME OF MANUFACTURE

LOAD CHART - MAIN BOOM, MID-SPAN OUTRIGGERS



MODEL 4000 142-ft BOOM

MAIN BOOM LOAD RATINGS WITH MIDSPAN OUTRIGGERS

LOAD RATINGS IN lbs WITH OUTRIGGERS AND STABILIZERS EXTENDED

LOAD RADIUS IN FEET	LOADED BOOM ANGLE	34-ft	LOADED BOOM ANGLE	A 47-ft	LOADED BOOM ANGLE	B 61-ft	LOADED BOOM ANGLE	C 74-ft	LOADED BOOM ANGLE	D 88-ft	LOADED BOOM ANGLE	E 101-ft	LOADED BOOM ANGLE	F 115-ft	LOADED BOOM ANGLE	G 128-ft	LOADED BOOM ANGLE	H 142-ft	
7	75.4	80,000																	
8	73.2	75,000																	
10	71.0	66,500	76.7	43,000															
12	67.3	56,100	74.3	43,000	79.1	43,000													
15	61.7	49,000	70.5	43,000	76.3	42,400	79.5	36,600											
20	50.9	33,000	63.6	34,000	71.4	34,000	75.7	31,700	78.7	24,900									
25	38.1	17,000	56.0	17,500	66.3	17,900	71.5	24,000	75.2	21,000	77.8	17,500							
30	19.3	11,800	47.8	12,300	60.6	12,700	67.2	13,000	71.7	13,100	75.0	16,000	77.5	13,400	79.3	11,500			
35			38.0	8,800	54.5	9,200	62.8	9,300	68.1	9,500	72.0	9,600	75.0	11,800	77.0	10,100	79.1	6,600	
40			25.2	6,500	48.0	6,600	58.0	6,800	64.4	6,900	68.8	7,100	72.2	8,900	74.9	8,900	77.0	6,600	
45					40.7	5,000	52.9	5,400	60.6	5,500	65.6	5,700	69.8	5,900	72.6	5,900	74.8	5,900	
50					31.9	3,800	47.3	4,200	56.5	4,400	62.3	4,600	67.0	4,700	70.1	4,700	72.7	4,700	
55					19.8	2,800	41.2	3,200	52.3	3,300	59.1	3,500	64.2	3,600	67.6	3,600	70.5	3,600	
60							34.9	2,400	48.0	2,500	55.5	2,600	61.2	2,700	65.0	2,700	68.3	2,700	
65							26.4	1,700	43.0	1,800	51.8	1,900	58.1	2,000	62.4	2,000	65.9	2,000	
70							12.9	1,100	37.3	1,200	47.6	1,300	55.0	1,400	59.7	1,400	63.6	1,400	
75									30.8	800	43.1	900	54.6	1,000	56.9	1,000	61.2	1,000	
80															54.0	700	58.7	700	
0		10,000	0	4,800	0	2,000	0	600											
DEDUCTIONS FOR STOWED EXTENDABLE JIB (lbs)		950		700		550		450		400		350		300		250		200	DEDUCTIONS FOR STOWED EXTENDABLE JIB (lbs)

NOTE:

- Operate jib by radius when main boom is fully extended.
Increase boom angle if necessary to maintain load radius.
- When boom is retracted, operate jib by boom angles.
Do not exceed any rated jib capacities at reduced boom lengths.
- Do not exceed capacities recommended by ASME/ANSI B30.5.
- Load ratings above bold line are structurally limited.
- Personnel handling is allowed only with full span outriggers.
- Boom load ratings are based on loaded boom radius.
Loaded boom angles are given as reference only.

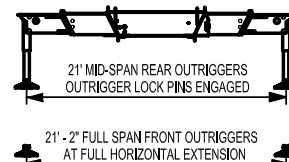
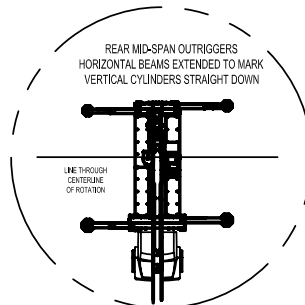

ELLIOTT EQUIPMENT CO. SUPPLIED LOADLINE EQUIPMENT DEDUCTIONS:

- DOWNHAUL WEIGHT.....225 lbs
- ONE SHEAVE BLOCK.....424 lbs
- TWO SHEAVE BLOCK.....592 lbs
- THREE SHEAVE BLOCK.....639 lbs
- FOUR SHEAVE BLOCK.....762 lbs
- AUXILIARY SHEAVE.....100 lbs

CRANE MEETS ASME B30.5 REQUIREMENTS AT TIME OF MANUFACTURE

RANGE CHART - MAIN BOOM, FULL-SPAN OUTRIGGERS



MODEL 4000

142-ft BOOM

RANGE DIAGRAM WITH FULLY EXTENDED OUTRIGGERS

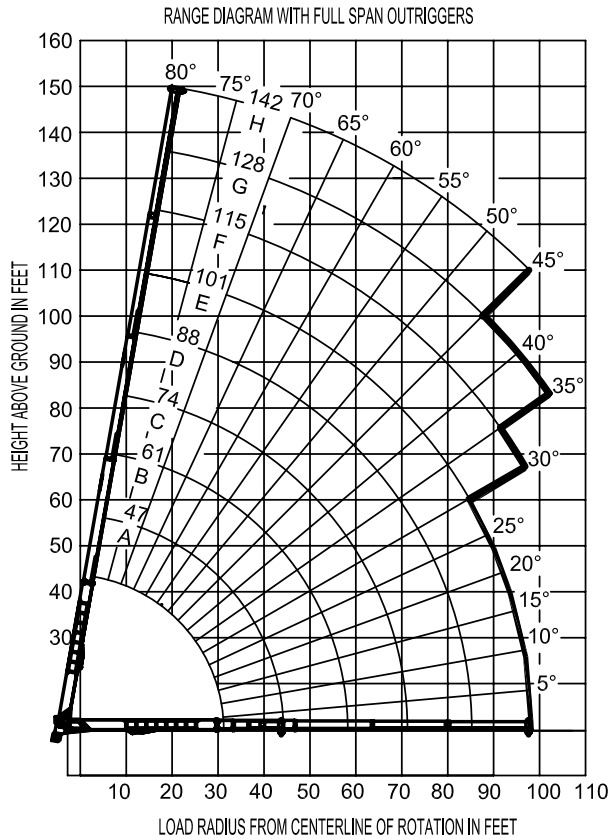

NOTE:

1. Operate jib by radius when main boom is fully extended. Increase boom angle if necessary to maintain load radius.
2. When boom is retracted, operate jib by boom angles. Do not exceed any rated jib capacities at reduced boom lengths.
3. Capacities do not exceed 85% stability.
4. Load ratings above bold line are structurally limited.
5. Personnel handling is allowed only with full span outriggers.
6. Boom load ratings are based on loaded boom radius. Loaded boom angles are given as reference only.

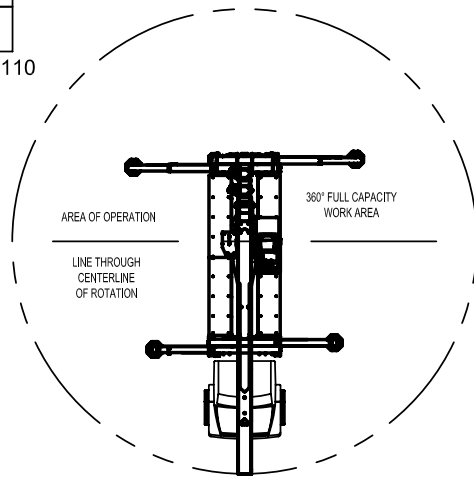
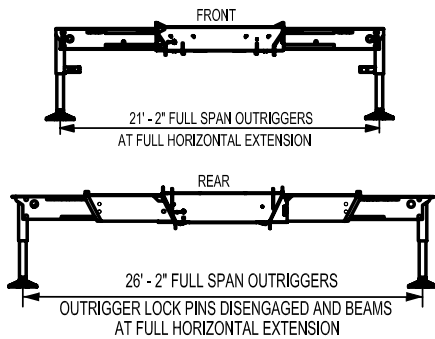

CRANE MEETS ASME B30.5 REQUIREMENTS AT TIME OF MANUFACTURE

RANGE CHART - MAIN BOOM, MID-SPAN OUTRIGGERS



MODEL 4000 142-ft BOOM

RANGE DIAGRAM WITH MID-SPAN OUTRIGGERS

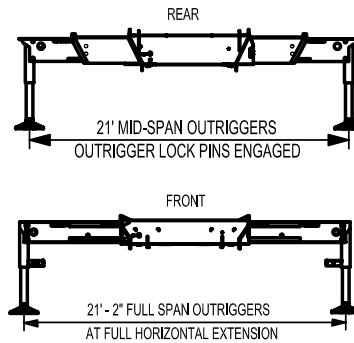
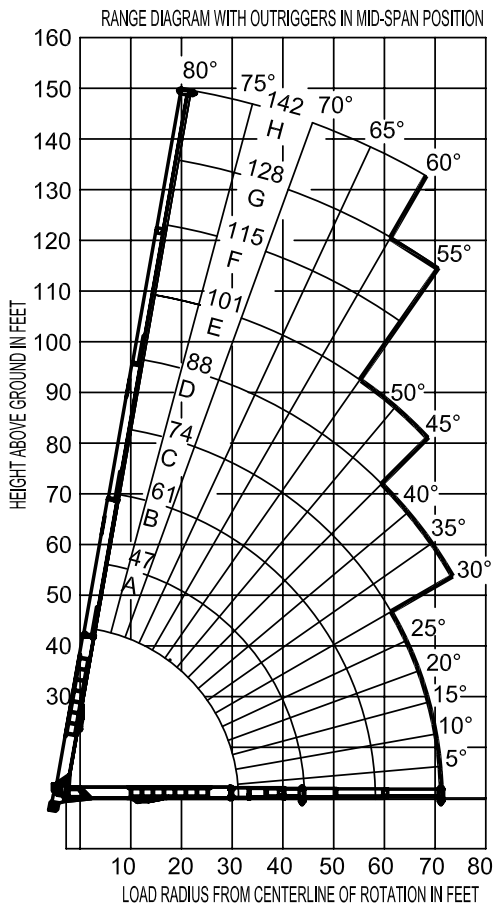

NOTE:

1. Operate jib by radius when main boom is fully extended. Increase boom angle if necessary to maintain load radius.
2. When boom is retracted, operate jib by boom angles. Do not exceed any rated jib capacities at reduced boom lengths.
3. Do not exceed capacities recommended by ASME/ANSI B30.5.
4. Load ratings above bold line are structurally limited.
5. Personnel handling is allowed only with full span outriggers.
6. Boom load ratings are based on loaded boom radius. Loaded boom angles are given as reference only.

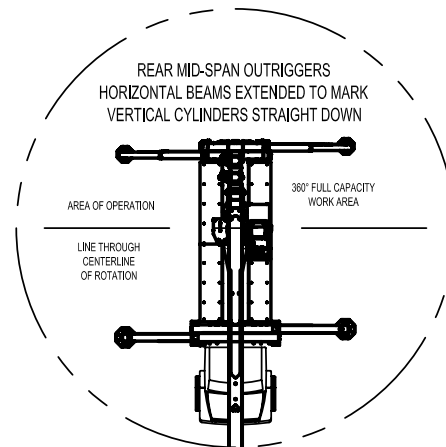

CRANE MEETS ASME B30.5 REQUIREMENTS AT TIME OF MANUFACTURE

LOAD CHART - TWO-SECTION JIB, FULL-SPAN OUTRIGGERS



MODEL 4000 142-ft BOOM

JIB LOAD RATINGS WITH FULLY EXTENDED OUTRIGGERS

32'-55' TWO SECTION JIB					
LOAD RADIUS IN FEET	LOADED BOOM ANGLE	32-ft JIB 360°	LOAD RADIUS IN FEET	LOADED BOOM ANGLE	55-ft JIB 360°
33	80	3,600	40	80	2,400
50	75	3,600	59	75	2,400
65	70	1,200	76	70	800
LMI MODE: 32'RET			LMI MODE: 55'EXT		

DO NOT OPERATE JIB IN WINDS EXCEEDING 15MPH

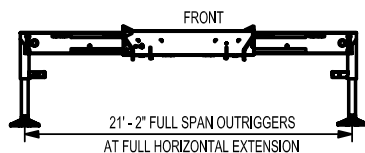
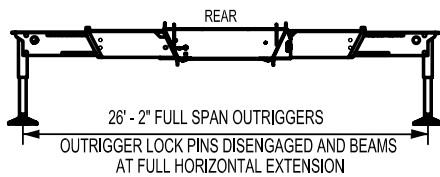

NOTE:

1. Operate jib by radius when main boom is fully extended. Increase boom angle if necessary to maintain load radius.
2. When boom is retracted, operate jib by boom angles. Do not exceed any rated jib capacities at reduced boom lengths.
3. Do not exceed capacities recommended by ASME/ANSI B30.5.
4. Load ratings above bold line are structurally limited.
5. Personnel handling is allowed only with full span outriggers.
6. Boom load ratings are based on loaded boom radius. Loaded boom angles are given as reference only.

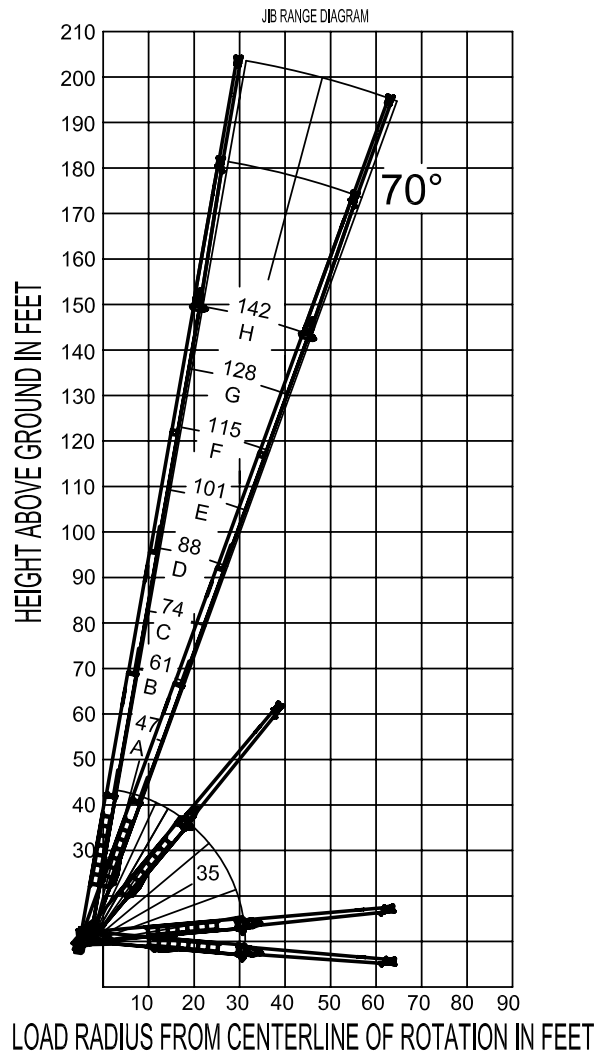

CRANE MEETS ASME B30.5 REQUIREMENTS AT TIME OF MANUFACTURE

RANGE CHART - MAIN BOOM, 600 LB (272 KG) PLATFORM ATTACHED



MODEL 4000

142-ft BOOM

BOOM RANGE DIAGRAM WITH PLATFORM ATTACHED

LOAD RADIUS IN FEET	LOADED BOOM LENGTH	LOADED BOOM ANGLE
81	81	0
77	88	24.9
79	101	38.9
80	115	47.8
80	128	54.0
80	142	58.7

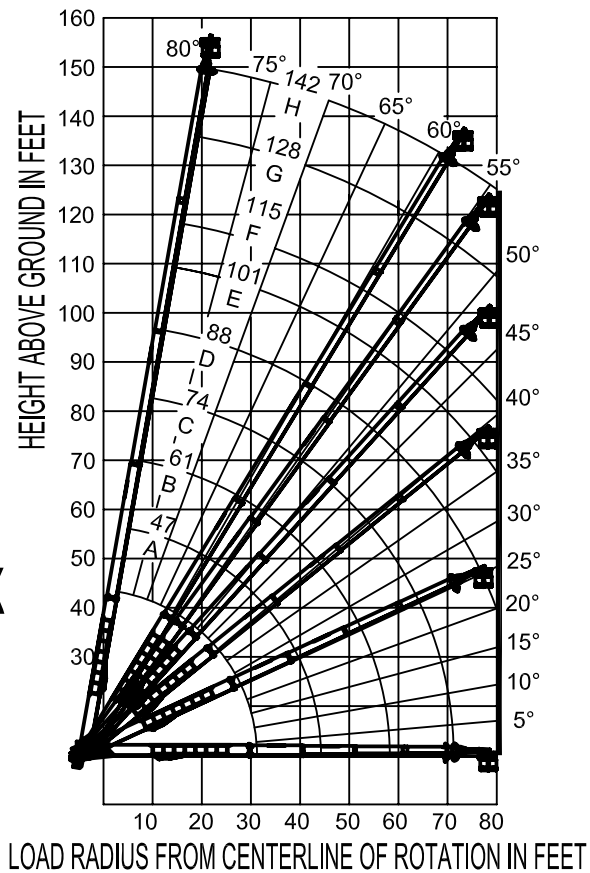

PERSONNEL 600 LBS MAX

**USE OUTRIGGERS
AT ALL TIMES**

NOTE:

1. Personnel handling is allowed only with full span outriggers.
2. Boom load ratings are based on loaded boom radius.
Loaded boom angles are given as reference only.

CRANE MEETS ASME B30.5 REQUIREMENTS AT TIME OF MANUFACTURE

RANGE CHART - MAIN BOOM, 1,200 LB (544 KG) PLATFORM ATTACHED



MODEL 4000

142-ft BOOM

BOOM RANGE DIAGRAM WITH PLATFORM ATTACHED

LOAD RADIUS IN FEET	LOADED BOOM LENGTH	LOADED BOOM ANGLE
72	72	0
70	74	12.9
70	88	37.3
70	101	47.6
70	115	55.0
70	128	59.7
70	142	63.6

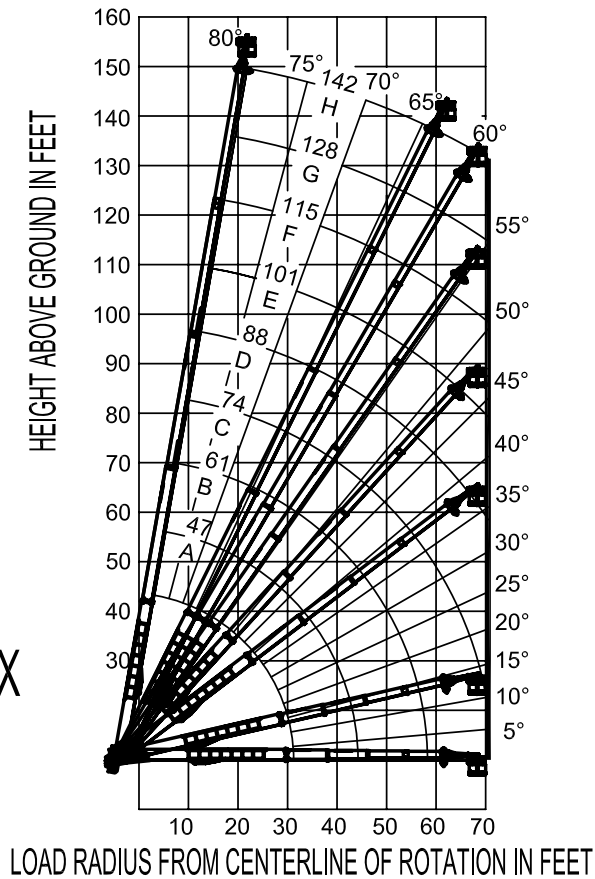

**PERSONNEL 1200LBS MAX
USE OUTRIGGERS
AT ALL TIMES**

NOTE:

1. Personnel handling is allowed only with full span outriggers.
2. Boom load ratings are based on loaded boom radius.
Loaded boom angles are given as reference only.

CRANE MEETS ASME B30.5 REQUIREMENTS AT TIME OF MANUFACTURE

RANGE CHART - 2-PIECE JIB, RETRACTED, 600 LB (272 KG) PLATFORM ATTACHED



MODEL 4000

142-ft BOOM

2 PIECE FULLY RETRACTED JIB RANGE DIAGRAM WITH PLATFORM ATTACHED

PERSONNEL 600LBS MAX
DO NOT OPERATE JIB IN WINDS EXCEEDING 15MPH
USE OUTRIGGERS AT ALL TIMES

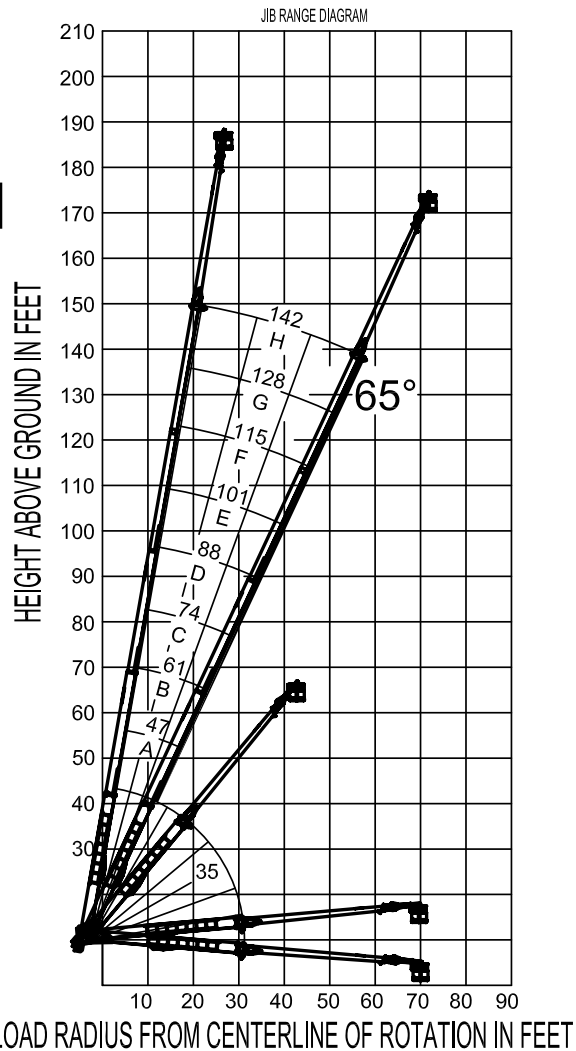

NOTE:

1. Operate jib by radius when main boom is fully extended. Increase boom angle if necessary to maintain load radius.
2. When boom is retracted, operate jib by boom angles. Do not exceed any rated jib capacities at reduced boom lengths.
3. Do not exceed capacities recommended by ASME/ANSI B30.5.
4. Load ratings above bold line are structurally limited.
5. Personnel handling is allowed only with full span outriggers.
6. Boom load ratings are based on loaded boom radius. Loaded boom angles are given as reference only.

CRANE MEETS ASME B30.5 REQUIREMENTS AT TIME OF MANUFACTURE



Elliott Equipment Company
 4427 South 76th Circle
 Omaha, NE 68127
 Phone: 402-592-4500
 Fax: 402-592-4553
 Email: sales@elliottequip.com

Built for You.
www.elliottequip.com

RANGE CHART - 2-PIECE JIB, EXTENDED, 600 LB (272 KG) PLATFORM ATTACHED



MODEL 4000

142-ft BOOM

2 PIECE FULLY EXTENDED JIB RANGE DIAGRAM WITH PLATFORM ATTACHED

PERSONNEL 600LBS MAX
DO NOT OPERATE JIB IN WINDS EXCEEDING 15MPH
USE OUTRIGGERS AT ALL TIMES

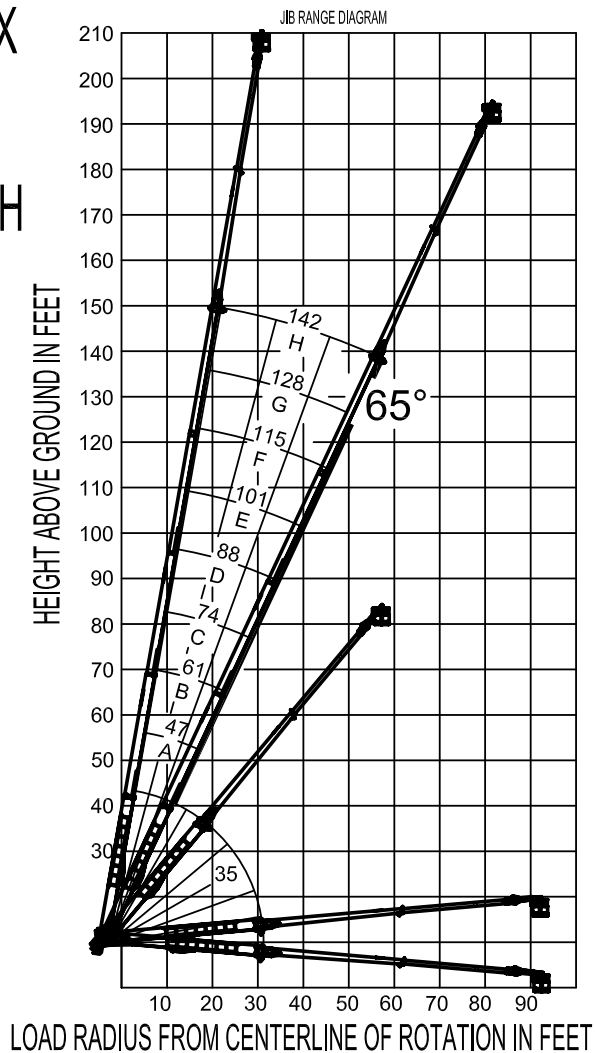

NOTE:

1. Operate jib by radius when main boom is fully extended.
Increase boom angle if necessary to maintain load radius.
2. When boom is retracted, operate jib by boom angles.
Do not exceed any rated jib capacities at reduced boom lengths.
3. Do not exceed capacities recommended by ASME/ANSI B30.5.
4. Load ratings above bold line are structurally limited.
5. Personnel handling is allowed only with full span outriggers.
6. Boom load ratings are based on loaded boom radius.
Loaded boom angles are given as reference only.

CRANE MEETS ASME B30.5 REQUIREMENTS AT TIME OF MANUFACTURE



Elliott Equipment Company
 4427 South 76th Circle
 Omaha, NE 68127
 Phone: 402-592-4500
 Fax: 402-592-4553
 Email: sales@elliottequip.com

Built for You.
www.elliottequip.com

RANGE CHART - 2-PIECE JIB, RETRACTED, 1,200 LB (544 KG) PLATFORM ATTACHED



MODEL 4000

142-ft BOOM

2 PIECE FULLY RETRACTED JIB RANGE DIAGRAM WITH PLATFORM ATTACHED

PERSONNEL 1200LBS MAX

DO NOT OPERATE JIB IN WINDS EXCEEDING 15MPH

USE OUTRIGGERS AT ALL TIMES

NOTE:

1. Operate jib by radius when main boom is fully extended.
Increase boom angle if necessary to maintain load radius.
2. When boom is retracted, operate jib by boom angles.
Do not exceed any rated jib capacities at reduced boom lengths.
3. Do not exceed capacities recommended by ASME/ANSI B30.5.
4. Load ratings above bold line are structurally limited.
5. Personnel handling is allowed only with full span outriggers.
6. Boom load ratings are based on loaded boom radius.
Loaded boom angles are given as reference only.

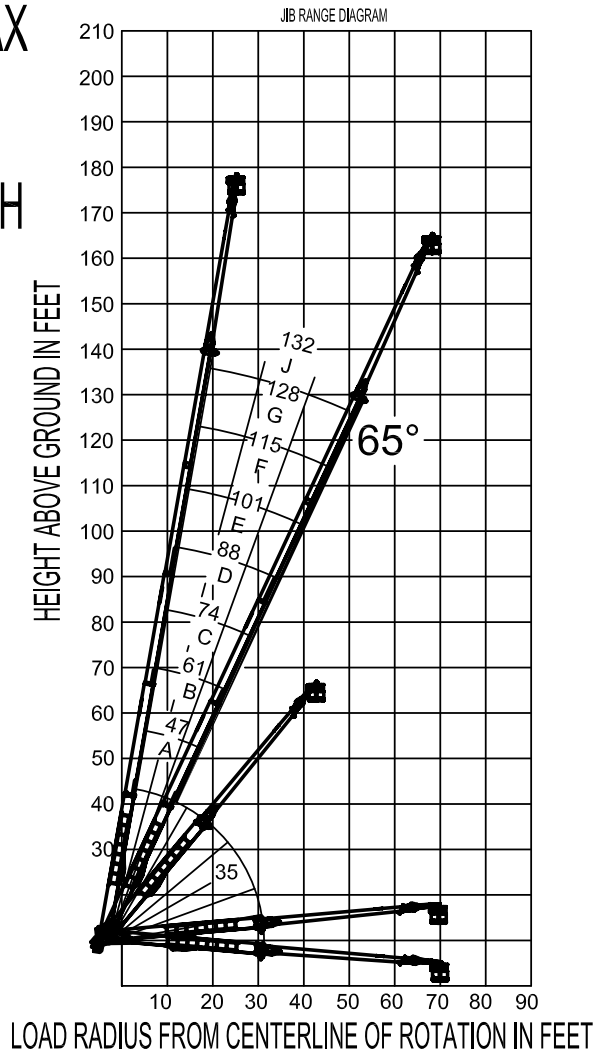

CRANE MEETS ASME B30.5 REQUIREMENTS AT TIME OF MANUFACTURE



Elliott Equipment Company
4427 South 76th Circle
Omaha, NE 68127
Phone: 402-592-4500
Fax: 402-592-4553
Email: sales@elliottequip.com

Built for You.
www.elliottequip.com

RANGE CHART - 2-PIECE JIB, EXTENDED, 1,200 LB (544 KG) PLATFORM ATTACHED



MODEL 4000

142-ft BOOM

2 PIECE FULLY EXTENDED JIB RANGE DIAGRAM WITH PLATFORM ATTACHED

PERSONNEL 1200LBS MAX

DO NOT OPERATE JIB IN WINDS EXCEEDING 15MPH

USE OUTRIGGERS AT ALL TIMES

NOTE:

1. Operate jib by radius when main boom is fully extended.
Increase boom angle if necessary to maintain load radius.
2. When boom is retracted, operate jib by boom angles.
Do not exceed any rated jib capacities at reduced boom lengths.
3. Do not exceed capacities recommended by ASME/ANSI B30.5.
4. Load ratings above bold line are structurally limited.
5. Personnel handling is allowed only with full span outriggers.
6. Boom load ratings are based on loaded boom radius.
Loaded boom angles are given as reference only.

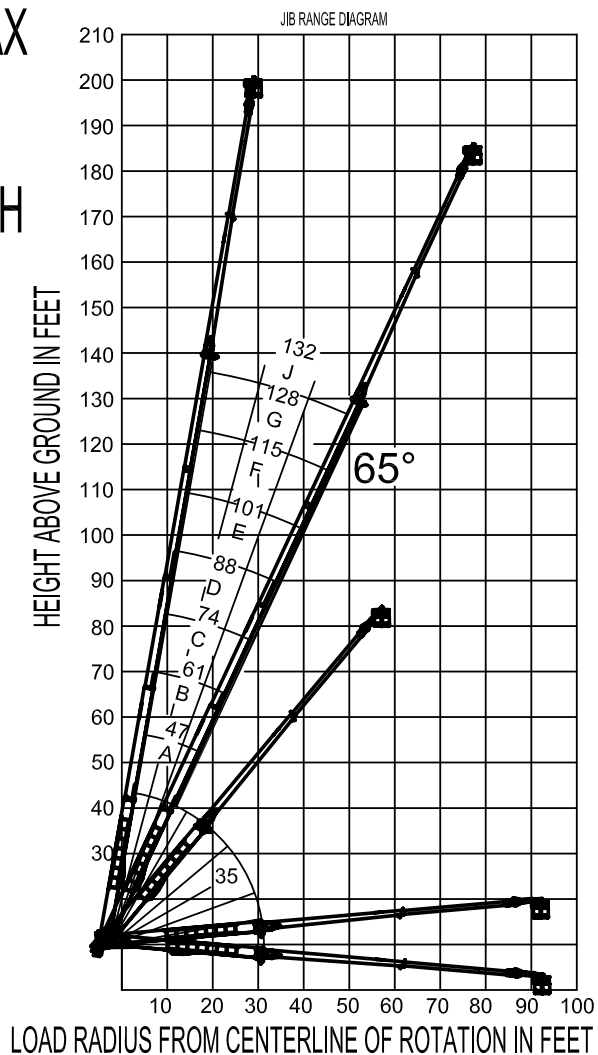

CRANE MEETS ASME B30.5 REQUIREMENTS AT TIME OF MANUFACTURE

MAIN BOOM WINCH DATA



MODEL 4000

142-ft BOOM

PARTS OF LINE

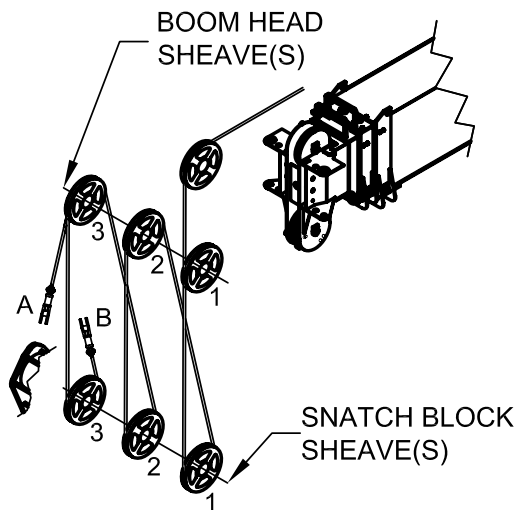

1-6 PARTS OF LINE

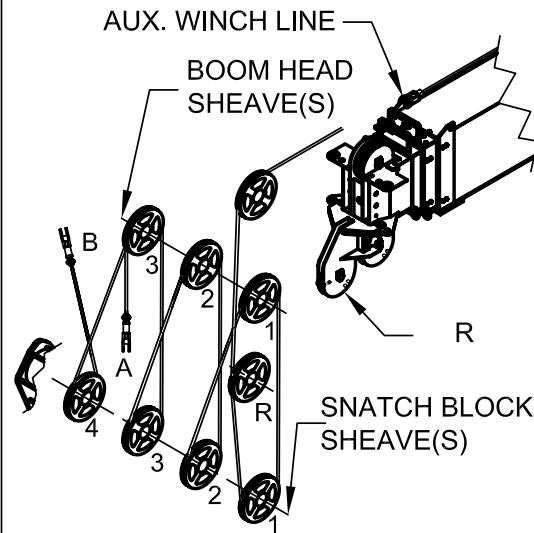

7-8 PARTS OF LINE

NOTICE:

- DO NOT DEADHEAD LINE BLOCK AGAINST BOOM TIP WHEN EXTENDING BOOM.
- KEEP AT LEAST 5 WRAPS OF LOADLINE ON THE WINCH DRUM AT ALL TIMES.
- USE ONLY 5/8" DIAMETER WIRE ROPE, AS SPECIFIED, WITH THE PROPER BREAKING STRENGTH LISTED.
- ANTI-TWO-BLOCK SYSTEM MUST BE IN GOOD OPERATING CONDITION BEFORE OPERATING CRANE. SEE OPERATION & SAFETY MANUAL.

PARTS OF LINE	SHEAVE(S) ON BOOM HEAD	SHEAVE(S) ON SNATCH BLOCK	5/8" - SPIN RESISTANT (5:1 S.F.) 50,000-lbs. BREAKING STRENGTH
1	1	A	10,000 lbs
2	1 B	1	20,000 lbs
3	1 2	1 A	30,000 lbs
4	1 2 B	1 2	40,000 lbs
5	1 2 3	1 2 A	50,000 lbs
6	1 2 3 B	1 2 3	60,000 lbs
7	R 1 2 3	R 1 2 3 A	70,000 lbs
8	R 1 2 3 B	R 1 2 3 A	80,000 lbs

A-DEAD END FOR ODD PARTS OF LINE
 B-DEAD END FOR EVEN PARTS OF LINE
 R-ROOSTER SHEAVE REQUIRED WHEN USING 7 AND 8 PARTS OF LINE

CRANE MEETS ASME B30.5 REQUIREMENTS AT TIME OF MANUFACTURE



Elliott Equipment Company
 4427 South 76th Circle
 Omaha, NE 68127
 Phone: 402-592-4500
 Fax: 402-592-4553
 Email: sales@elliottequip.com

Built for You.
www.elliottequip.com

TRUCK CHASSIS SPECIFICATIONS

	40142 BoomTruck
Wheelbase (WB)	309" / 785 cm
Cab to Axle (CA/CT)	219" / 556 cm
Cab to End of Frame (EOF)	Contact Factory
Frame Section Modulus	30.0 in3-110,000 psi / 758 428 kPa
Front Axle Gross Weight Rating	20,000 lb / 9072 kg
Rear Axle Gross Weight Rating	58,000 lb / 26 308 kg
Permit-Free Truck Configurations	Contact Factory for More Information

Chassis data is minimum general requirements-not for engineering.
 Actual dimensions and truck data will depend on truck selection and axle configuration.
 *Minimum chassis weight is required to meet 85% stability requirements.

OPTIONS



Radio Remote Control

Interference protected radio remotes let you get closer to your work and have full control over your machine. Optional LMI display is available.

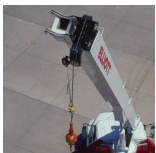

Pin-On Jib Attachments

One piece & two piece telescoping or fixed jibs that stow on the side of the boom for easy setup while on the jobsite.



Air Conditioning in Crane Cab

Work all day in comfort with an high efficiency air conditioning system mounted on the rear of the crane control cab.



Dual Winch System & Drum Indicators

Take advantage of Elliott's auxiliary dual winch package with optional drum rotation indicators.



Tool Boxes

Optional tool boxes and bed storage can accommodate any storage need for tools, work materials and more.

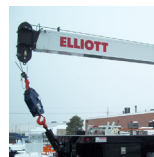

Hook Block for Multi-Part Line

Elliott can include a hook block device for up to 8 parts of line to improve lifting capabilities and allow you to maximize your use of the crane.



2-Man Yoke Work Platform

Elliott's new 1,200 lb capacity 2-man platform features hydraulic yoke lifting system for easy attachment to the boom tip. Fully OSHA compliant and heavy duty.



Body Mounted Hose Reels and Circuits

Let us work with you to customize your tool compatability by adding hose reels or hydraulic circuits to the crane bed.

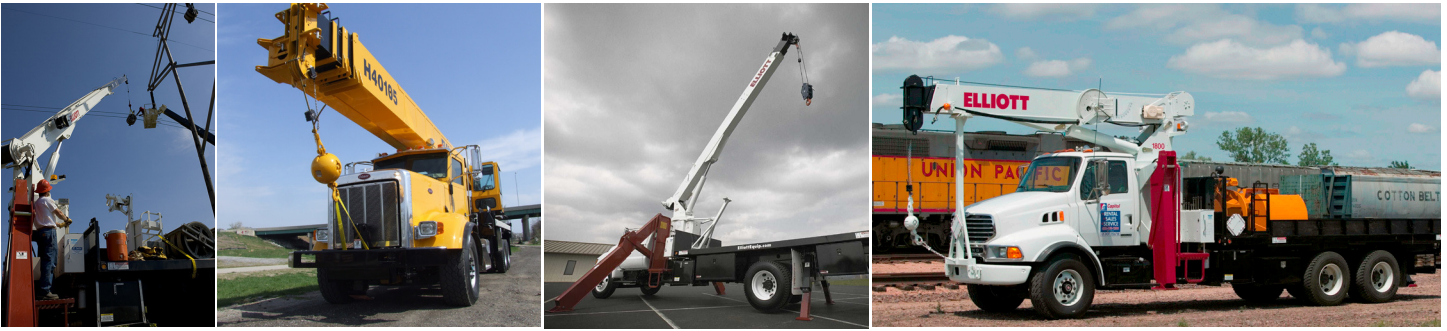

45127 SIDE VIEW DIAGRAM

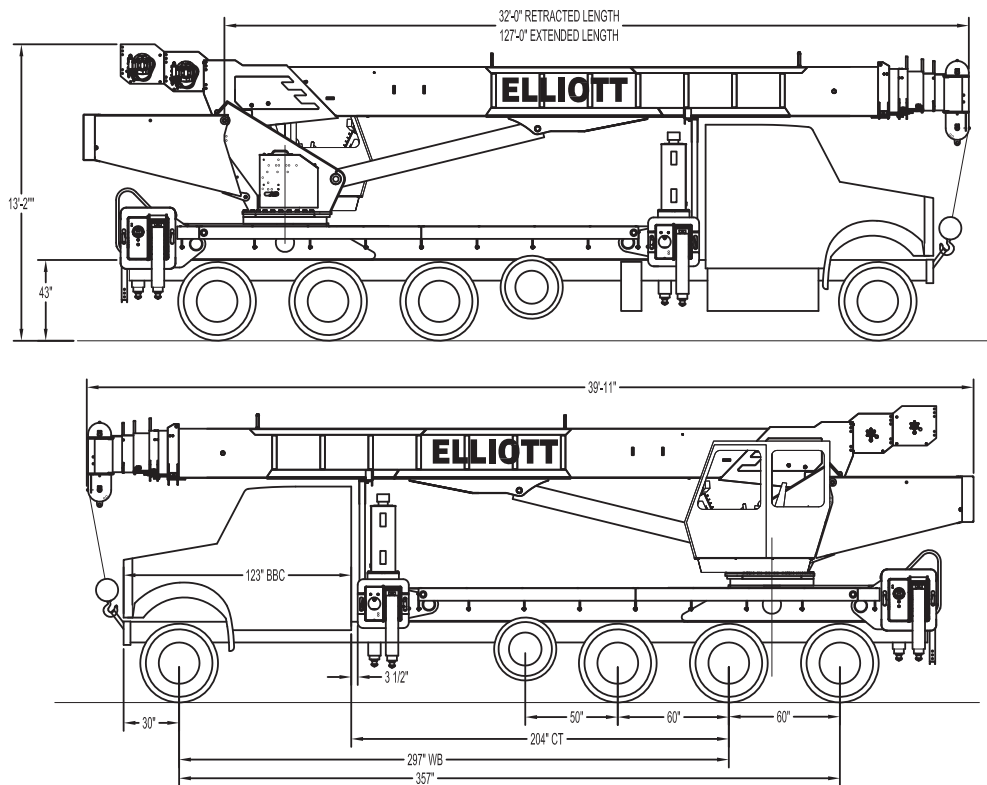

- | | | | |
|----------------------------------|----------------------|---------------------------------|--------------------------------|
| • Maximum Vertical Reach | 192'/58,5 m | • Powered Boom Sections | 5 |
| • Working Area | 360 Degrees | • Overall Height | 13'2"/4 m |
| • Lifting Capacity | 90,000 lbs/40 823 kg | • Operator Controls | Rotating Cab with Control Seat |
| • Boom Length | 127'/38,7 m | • Outrigger Type Front | Out-Down |
| • Crane Weight (Standard) | 43,000 lbs/19 504 kg | • Outrigger Spread Front | 21'2"/6,4 m |
| • Jib Lengths | 32'-55' / 9,7-16,7 m | • Outrigger Type Rear | Out-Down |
| • Winch Bare Drum Pull | 15,000 lbs/6804 kg | • Outrigger Spread Rear | 26'2"/8 m |

TECHNICAL SPECIFICATIONS

Crane Capacity: 90,000 lbs at 7' radius.

Maximum Tip Height: 137' tip height (192' with 55' jib).

Control Console: Rotating seated controls with operator cab and deluxe operators seat. Station equipped with four pilot operated control levers for the main crane controls. Operator station includes LMI display, diesel heater, bubble level gauge, engine start/stop switch, signal horn button, variable speed throttle switch, lifting capacity chart, range diagram chart, boom angle indicator, system pressure gauge, 12V DC power source, and cup holder. Independent ground level electric operated outrigger controls.

Boom: Five-section fully proportional, high strength steel plated rectangular tube sections. A maximum boom tip height of 137' mounted on a truck. The boom nose contains one floating upper sheave and three lower sheaves. Assembly includes heavy-duty cylinder fittings, pivot pins, and replaceable wear pads.

Winch: Mounted at the base of the boom for a long fleet angle and flat level spooling of cable. Winch is driven by a planetary reducer and powered by a hydraulic motor. Burst-of-speed winch provides increased line speed. The winch brake is spring applied, pressure release design. Supplied with 430' of 5/8" diameter rotation resistant wire rope with a single line pull of 10,000 lbs., and a downhaul ball with swivel hook for single part line.

Load Moment Indicator System: System senses hoist cylinder pressures, boom length and boom angle with hydraulic function lockout. The display console is equipped with a bar graph showing crane utilization, boom angle or boom length, a mode select controls for main boom and jib operation, and an anti-two block with an audio/visual warning and shut-off functions to limit hook-boom point contact.

Elliott Equipment Company reserves the right to change the specification of any unit at any time without prior notice. This brochure is only a statement of general specifications on the date of this publication. For more detailed info on specific Elliott trucks go to www.elliottequip.com

Outriggers: Two sets of out and down overframe outriggers. Front outriggers have a 21'2" span, rear outriggers have a 26'2" span. Outriggers are configured for full span or mid span operation. Outriggers equipped with 22" diameter ball socket aluminum removable pads that stow on vertical outrigger legs.

Frame: Full length, all welded rigid 4-plate design sub-frame. Sub-frame allows for bolt-on addition of aluminum bed wings, with top plate of subbase serving as a portion of the bed deck, to form a three-piece bed.

Turret: Reverse offset turret is one-piece weldment. Turret rotates on large diameter ball bearing.

Rotation: Hydraulic motor drives turret through double reduction planetary swing drive for 360 degree continuous rotation. Glide-swing drive system has manual foot applied brake

Lift: One double-acting long stroke cylinder provides smooth and stable boom elevation. Holding valve prevents boom from falling in event of hose failure.

Boom Extension: Incorporates a 2-stage hydraulic extension cylinder, attached to the largest boom section, with a proportional cable extension system driving the outermost sections.

Hoses: All high pressure hoses are wire braid reinforced with a minimum safety factor of 4 to 1.

Cylinders: All cylinders use microhoned cylinder tubing, chrome shafts, top grade packing and protective rod wipers. Cylinder-mounted holding valves provided on all load-holding cylinders.

Hydraulic System: Equipped with air-shift PTO, piston pump, SAE O-ring face seals on pressure lines, and a 10-micron return line filter. Hydraulic oil cooler. The control valve distributes all flow to hoist system, swing circuit, and other crane functions. System is closed center type.

Oil Tank Capacity: 143 gallon mounted to top of frame.

Cab Equipment: Air shift PTO with indicator lights installed in truck cab. U/L approved 5:BC dry chemical fire extinguisher installed in truck cab.

Operators Manual & Video: Two CD copies and one hard copy of operation, maintenance, safety and parts manual provided with each unit. Operational and safety video provided at delivery.

Installation: Unit installed on chassis, painted, system and tank filled with oil, tested, inspected, and ready to operate.

Standard Paint: Paint turret and boom white, outriggers red, and bed and boxes black.

Bumper: Bureau of Motor Carrier Safety rear bumper.

Weight: Approximately 43,000 lbs. less truck.

Truck Chassis Required: Approx. 204" C.T., RBM 3,300,000 in-lb. per rail, 20,000 lb. front axle, 66,000 lb. tridem rear axles, and 8,000 lb pusher axle ahead of tridem. 94,000 lb. GVWR required. Trucks must have 12V electrical system with high capacity alternator, cab clearance stop/tail/backup lights, and I.D. lamps. Additional configurations available for bridge legal cranes and export. Contact factory when additional equipment is to be added.

Options:

Air Conditioning for Crane Cab.
32'-55' 2-Stage Telescopic Jib
Gravity Leveled Work Platform.
Wireless Radio Remote Controls.
Winch Drum Rotation Indicator.
Auxiliary Winch Package.
Work Area Definition (WADS)
Much More...

LOAD CHART - FULL SPAN OUTRIGGERS



MODEL 4500 127-ft BOOM

MAIN BOOM LOAD RATINGS WITH FULLY EXTENDED OUTRIGGERS

MAIN BOOM LOAD RATINGS

LOAD RATINGS IN lbs WITH OUTRIGGERS AND STABILIZERS EXTENDED

LOAD RADIUS IN FEET	LOADED BOOM ANGLE	32-ft	LOADED BOOM ANGLE	A 43-ft	LOADED BOOM ANGLE	B 55-ft	LOADED BOOM ANGLE	C 67-ft	LOADED BOOM ANGLE	D 79-ft	LOADED BOOM ANGLE	E 91-ft	LOADED BOOM ANGLE	F 103-ft	LOADED BOOM ANGLE	G 115-ft	LOADED BOOM ANGLE	H 127-ft	
7	73.6	90,000																	
8	71.6	81,400																	
10	67.6	69,600	74.2	43,000															
12	63.4	57,600	71.4	43,000	75.8	43,000	78.8	41,000											
15	56.8	46,000	67.0	40,000	72.6	43,000	76.2	37,800	78.6	29,000	80.4	21,850							
20	44.4	33,200	59.4	33,700	66.9	34,100	71.7	33,800	74.9	25,500	77.2	19,400	79.2	16,300	80.7	12,850			
25	27.8	24,900	51.0	25,450	61.0	25,900	67.0	26,100	71.1	22,200	74.0	17,250	76.5	14,950	78.4	12,600	79.9	10,000	
30			41.4	20,250	54.6	20,700	62.1	20,900	67.2	20,150	70.8	15,650	73.7	13,700	76.0	11,800	77.9	9,900	
35			29.4	16,450	47.8	16,700	57.0	16,950	63.1	17,100	67.4	14,500	70.8	12,650	73.7	10,950	75.8	9,500	
40			7.2	13,000	40.0	13,300	51.6	13,500	58.8	13,700	63.9	13,250	67.9	11,600	71.2	10,300	73.6	9,000	
45					30.6	10,800	45.7	11,000	54.3	11,100	60.3	11,200	65.1	10,700	68.6	9,600	71.4	8,600	
50					18.5	9,000	39.8	9,200	50.0	9,400	56.8	9,500	62.0	9,500	65.9	9,000	69.0	8,100	
55							32.2	7,700	44.8	7,850	52.7	7,900	58.6	8,000	63.1	8,000	66.7	7,650	
60							22.3	6,500	39.2	6,600	48.4	6,700	55.1	6,800	60.1	6,800	64.2	6,800	
65									32.7	5,600	43.9	5,700	51.4	5,800	57.0	5,800	61.5	5,750	
70									24.7	4,700	38.9	4,800	47.5	4,900	53.7	5,000	58.6	4,900	
75									12.4	4,000	33.2	4,000	43.3	4,100	50.3	4,250	55.7	4,200	
80											26.5	3,450	38.8	3,500	46.8	3,600	52.7	3,550	
85											17.4	2,850	33.8	2,900	43.0	3,000	49.5	3,000	
90													28.0	2,450	38.9	2,500	46.2	2,450	
95													20.6	2,000	34.3	2,050	42.7	2,000	
100													7.1	1,650	29.2	1,650	38.9	1,600	
105															22.9	1,300	34.8	1,300	
110															13.9	950	30.1	1,000	
115																	24.7	700	
	0	21,200	0	12,900	0	8,200	0	5,600	0	3,800	0	2,500	0	1,600	0	800			
JIB DEDUCTIONS	950		700		550		450		400		350		300		250		200		DEDUCTIONS FOR STOWED EXTENDABLE JIB (lbs)
	750		550		450		350		300		250		200		200		150		DEDUCTIONS FOR STOWED FIXED JIB (lbs)

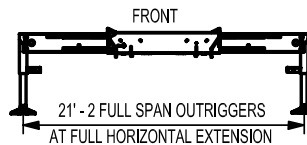
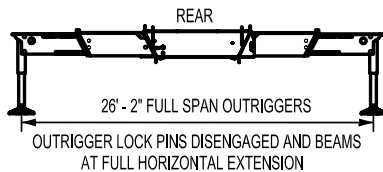

ELLIOTT EQUIPMENT CO. SUPPLIED LOADLINE EQUIPMENT DEDUCTIONS:
 DOWNHAUL WEIGHT.....225 lbs
 ONE SHEAVE BLOCK.....424 lbs
 TWO SHEAVE BLOCK.....592 lbs
 THREE SHEAVE BLOCK.....639 lbs
 FOUR SHEAVE BLOCK.....762 lbs
 AUXILIARY SHEAVE.....100 lbs

CRANE MEETS ASME B30.5 REQUIREMENTS AT TIME OF MANUFACTURE

DO NOT PAINT OVER ANY LABELS 1181460 092012



Elliott Equipment Company
 4427 South 76th Circle
 Omaha, NE 68127
 Phone: 402-592-4500
 Fax: 402-592-4553
 Email: sales@elliottequip.com

Built for You.
 www.elliottequip.com

LOAD CHART - MID SPAN OUTRIGGERS



MODEL 4500 127-ft BOOM

MAIN BOOM LOAD RATINGS WITH MIDSPAN OUTRIGGERS

LOAD RATINGS IN lbs WITH OUTRIGGERS AND STABILIZERS EXTENDED

LOAD RADIUS IN FEET	LOADED BOOM ANGLE	32-ft	A	LOADED BOOM ANGLE	B	LOADED BOOM ANGLE	C	LOADED BOOM ANGLE	D	LOADED BOOM ANGLE	E	LOADED BOOM ANGLE	F	LOADED BOOM ANGLE	G	LOADED BOOM ANGLE	H	
		32-ft	43-ft	55-ft	67-ft	79-ft	91-ft	103-ft	115-ft	127-ft								
7	73.6	90,000																
8	71.6	81,400																
10	67.6	69,600	74.2	43,000														
12	63.4	57,600	71.4	43,000	75.8	43,000	78.8	41,000										
15	56.8	46,000	67.0	40,000	72.6	43,000	76.2	37,800	78.6	29,000	80.4	21,850						
20	44.4	33,000	59.4	33,000	66.9	34,100	71.7	33,800	74.9	25,500	77.2	19,400	79.2	16,300	80.7	12,850		
25	27.8	24,000	51.0	24,000	61.0	25,000	67.0	25,000	71.1	22,200	74.0	17,250	76.5	14,950	78.4	12,600	79.9	10,000
30			41.4	16,000	54.6	16,000	62.1	16,000	67.2	15,700	70.8	15,650	73.7	13,700	76.0	11,800	77.9	9,900
35			29.4	12,400	47.8	12,400	57.0	12,700	63.1	12,700	67.4	12,900	70.8	12,650	73.7	10,950	75.8	9,500
40			7.2	9,700	40.0	10,000	51.6	10,300	58.8	10,300	63.9	10,300	67.9	10,300	71.2	10,300	73.6	9,000
45					30.6	8,000	45.7	8,300	54.3	8,300	60.3	8,300	65.1	8,400	68.6	8,500	71.4	8,600
50					18.5	6,700	39.8	6,700	50.0	6,700	56.8	6,800	62.0	6,900	65.9	7,000	69.0	7,000
55							32.2	5,500	44.8	5,500	52.7	5,600	58.6	5,600	63.1	5,700	66.7	5,700
60							22.3	4,500	39.2	4,500	48.4	4,500	55.1	4,500	60.1	4,600	64.2	4,600
65									32.7	3,500	43.9	3,500	51.4	3,500	57.0	3,600	61.5	3,700
70									24.7	2,600	38.9	2,600	47.5	2,700	53.7	2,800	58.6	2,900
75									12.4	2,000	33.2	2,000	43.3	2,000	50.3	2,100	55.7	2,200
80											26.5	1,400	38.8	1,400	46.8	1,500	52.7	1,600
85											17.4	1,000	33.8	1,000	43.0	1,100	49.5	1,100
90																		
	0	21,000	0	9,500	0	6,000	0	3,400	0	1,900								
JIB DEDUCTIONS		950		700		550		450		400		350		300		250		200
		750		550		450		350		300		250		200		200		150

NOTE:

- Operate jib by radius when main boom is fully extended. Increase boom angle if necessary to maintain load radius.
- When boom is retracted, operate jib by boom angles. Do not exceed any rated jib capacities at reduced boom lengths.
- Do not exceed capacities recommended by ASME/ANSI B30.5.
- Load ratings above bold line are structurally limited.
- Personnel handling is allowed only with full span outriggers.
- Boom load ratings are based on loaded boom radius. Loaded boom angles are given as reference only.

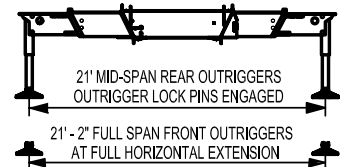
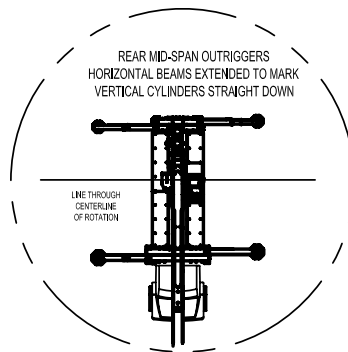

ELLIOTT EQUIPMENT CO. SUPPLIED LOADLINE EQUIPMENT DEDUCTIONS:

- DOWNHAUL WEIGHT225 lbs
- ONE SHEAVE BLOCK.....424 lbs
- TWO SHEAVE BLOCK.....592 lbs
- THREE SHEAVE BLOCK.....639 lbs
- FOUR SHEAVE BLOCK.....762 lbs
- AUXILIARY SHEAVE.....100 lbs

CRANE MEETS ASME B30.5 REQUIREMENTS AT TIME OF MANUFACTURE

DO NOT PAINT OVER ANY LABELS 1181460 092012



Elliott Equipment Company
4427 South 76th Circle
Omaha, NE 68127
Phone: 402-592-4500
Fax: 402-592-4553
Email: sales@elliottequip.com

Built for You.
www.elliottequip.com

RANGE CHART - FULL SPAN OUTRIGGERS, NO JIB



MODEL 4500 127-ft BOOM

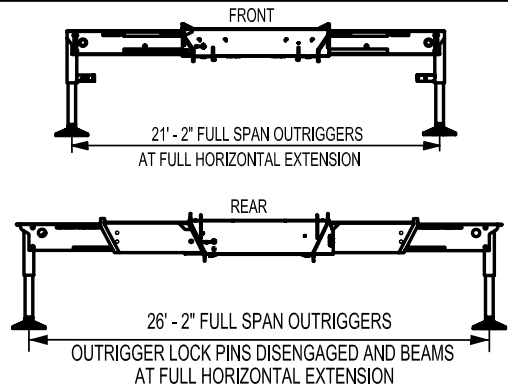
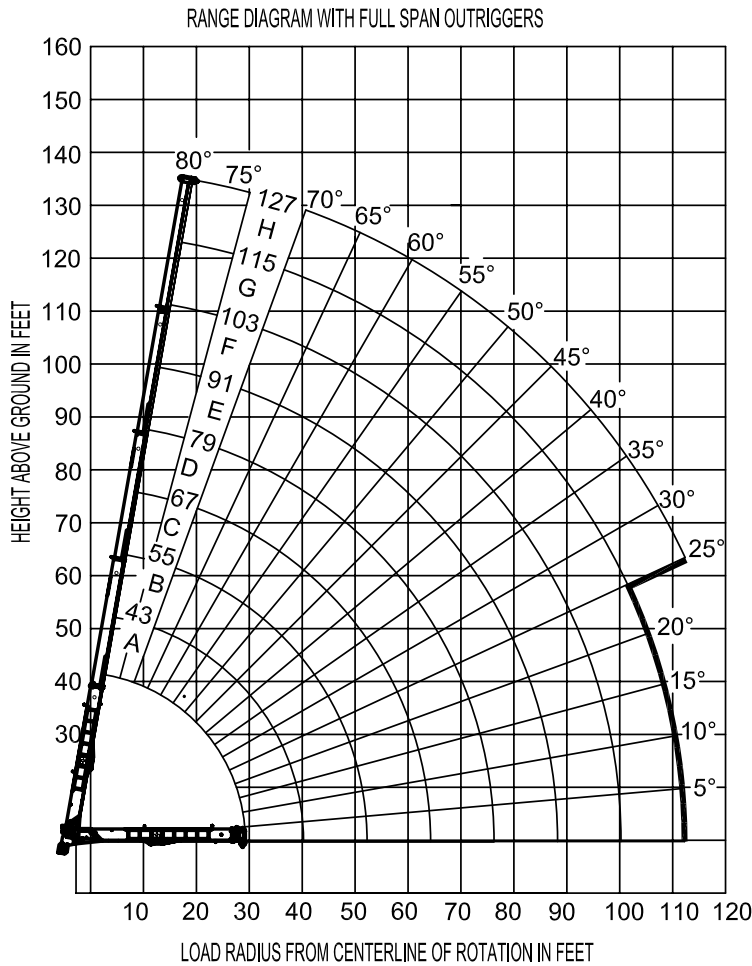

NOTE:

1. Operate jib by radius when main boom is fully extended. Increase boom angle if necessary to maintain load radius.
2. When boom is retracted, operate jib by boom angles. Do not exceed any rated jib capacities at reduced boom lengths.
3. Capacities do not exceed 85% stability.
4. Load ratings above bold line are structurally limited.
5. Personnel handling is allowed only with full span outriggers.
6. Boom load ratings are based on loaded boom radius. Loaded boom angles are given as reference only.

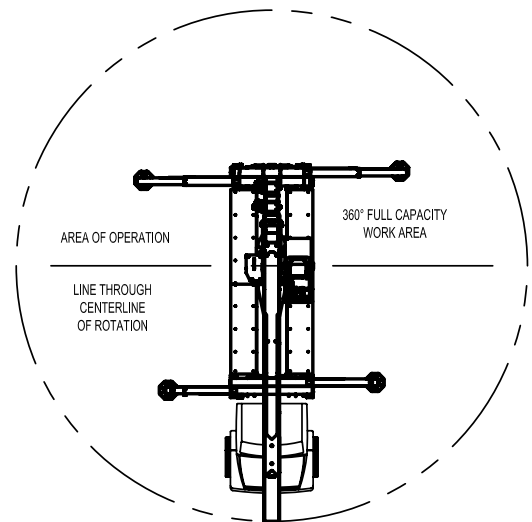

CRANE MEETS ASME B30.5 REQUIREMENTS AT TIME OF MANUFACTURE

DO NOT PAINT OVER ANY LABELS

1181460 092012

RANGE CHART - MID-SPAN OUTRIGGERS, NO JIB



MODEL 4500 127-ft BOOM

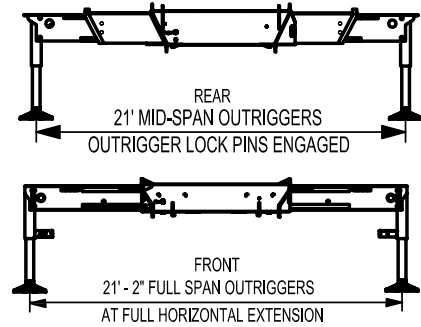
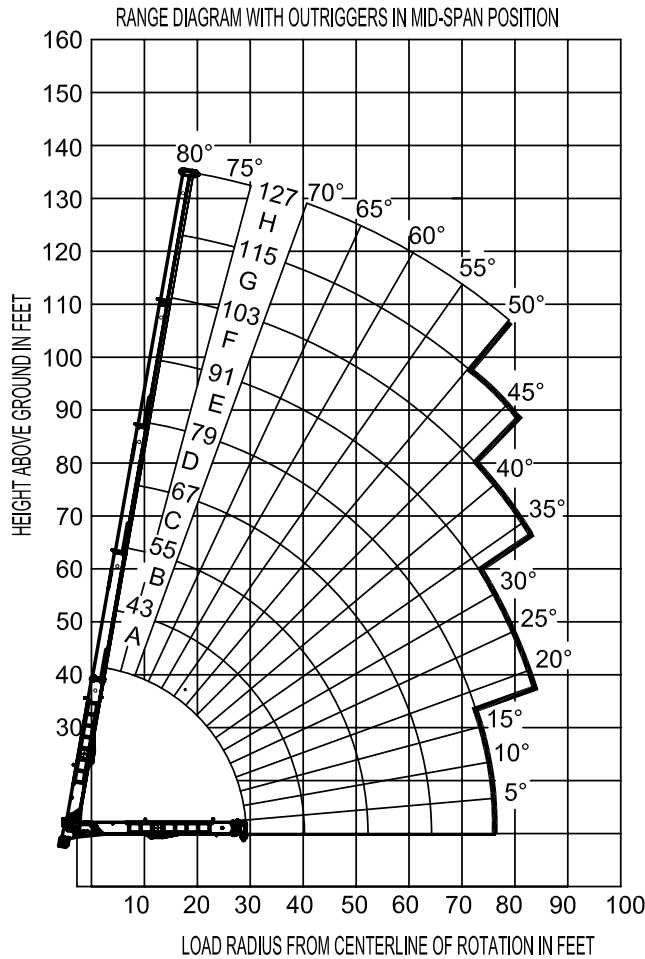

NOTE:

1. Operate jib by radius when main boom is fully extended. Increase boom angle if necessary to maintain load radius.
2. When boom is retracted, operate jib by boom angles. Do not exceed any rated jib capacities at reduced boom lengths.
3. Do not exceed capacities recommended by ASME/ANSI B30.5.
4. Load ratings above bold line are structurally limited.
5. Personnel handling is allowed only with full span outriggers.
6. Boom load ratings are based on loaded boom radius. Loaded boom angles are given as reference only.

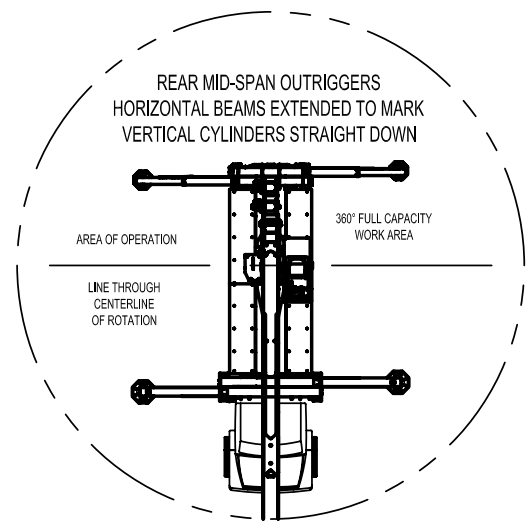

CRANE MEETS ASME B30.5 REQUIREMENTS AT TIME OF MANUFACTURE

DO NOT PAINT OVER ANY LABELS

1181460 092012



Elliott Equipment Company
 4427 South 76th Circle
 Omaha, NE 68127
 Phone: 402-592-4500
 Fax: 402-592-4553
 Email: sales@elliottequip.com

Built for You.
www.elliottequip.com

JIB CHART - FULL-SPAN OUTRIGGERS, 32'-55' TWO SECTION JIB



MODEL 4500

127-ft BOOM

JIB LOAD RATINGS WITH FULLY EXTENDED OUTRIGGERS

32'-55' TWO SECTION JIB					
LOAD RADIUS IN FEET	LOADED BOOM ANGLE	32-ft JIB 360°	LOAD RADIUS IN FEET	LOADED BOOM ANGLE	55-ft JIB 360°
30	80	3,600	36	80	2,400
46	75	3,600	54	75	2,400
60	70	1,200	70	70	800
LMI MODE: 32'RET			LMI MODE: 55'EXT		

DO NOT OPERATE JIB IN WINDS EXCEEDING 15MPH

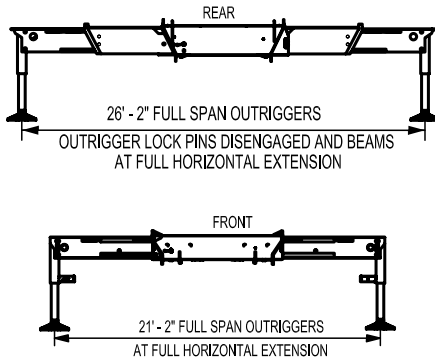

NOTE:

1. Operate jib by radius when main boom is fully extended. Increase boom angle if necessary to maintain load radius.
2. When boom is retracted, operate jib by boom angles. Do not exceed any rated jib capacities at reduced boom lengths.
3. Do not exceed capacities recommended by ASME/ANSI B30.5.
4. Load ratings above bold line are structurally limited.
5. Personnel handling is allowed only with full span outriggers.
6. Boom load ratings are based on loaded boom radius. Loaded boom angles are given as reference only.

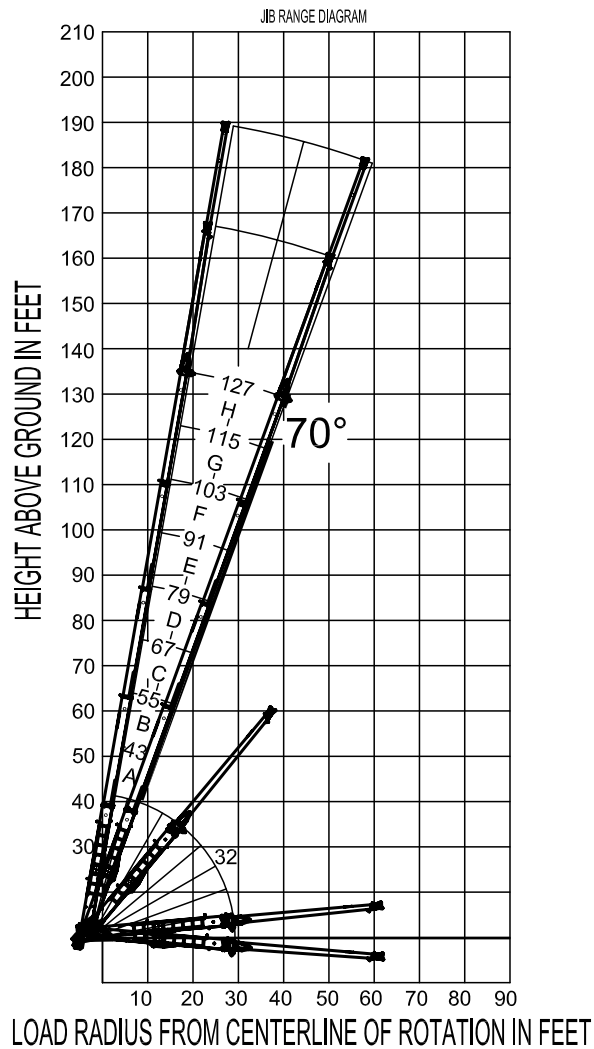

CRANE MEETS ASME B30.5 REQUIREMENTS AT TIME OF MANUFACTURE

1181460 110912



Elliott Equipment Company
 4427 South 76th Circle
 Omaha, NE 68127
 Phone: 402-592-4500
 Fax: 402-592-4553
 Email: sales@elliottequip.com

Built for You.
www.elliottequip.com

RANGE CHART - 2-MAN BASKET 600 LB / 272 KG CAPACITY



MODEL 4500

127-ft BOOM

BOOM RANGE DIAGRAM WITH PLATFORM ATTACHED

LOAD RADIUS IN FEET	LOADED BOOM LENGTH	LOADED BOOM ANGLE
91	91	0
90	103	28.0
90	115	38.9
90	127	46.2

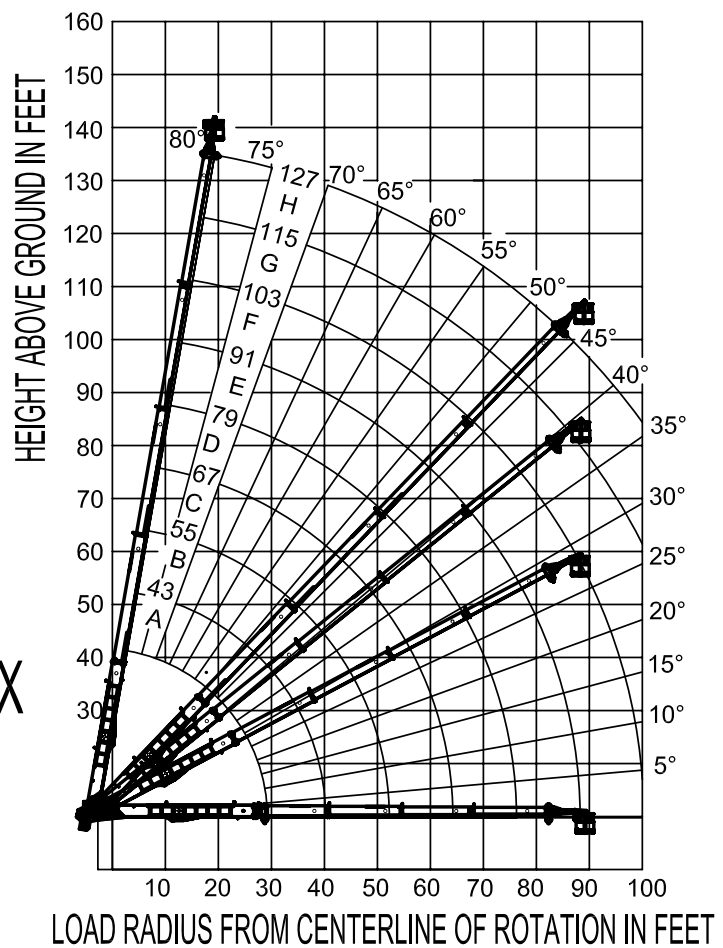

PERSONNEL 600 LBS MAX

**USE OUTRIGGERS
AT ALL TIMES**

- NOTE:
1. Personnel handling is allowed only with full span outriggers.
 2. Boom load ratings are based on loaded boom radius.
Loaded boom angles are given as reference only.

CRANE MEETS ASME B30.5 REQUIREMENTS AT TIME OF MANUFACTURE

DO NOT PAINT OVER ANY LABELS

1181460 092012



Elliott Equipment Company
4427 South 76th Circle
Omaha, NE 68127
Phone: 402-592-4500
Fax: 402-592-4553
Email: sales@elliottequip.com

Built for You.
www.elliottequip.com

RANGE CHART - 2-MAN BASKET 1,200 LB / 544 KG CAPACITY



MODEL 4500

127-ft BOOM

BOOM RANGE DIAGRAM WITH PLATFORM ATTACHED

LOAD RADIUS IN FEET	LOADED BOOM LENGTH	LOADED BOOM ANGLE
81	79	0
79	91	28.3
79	103	39.6
80	115	46.8
80	127	52.9

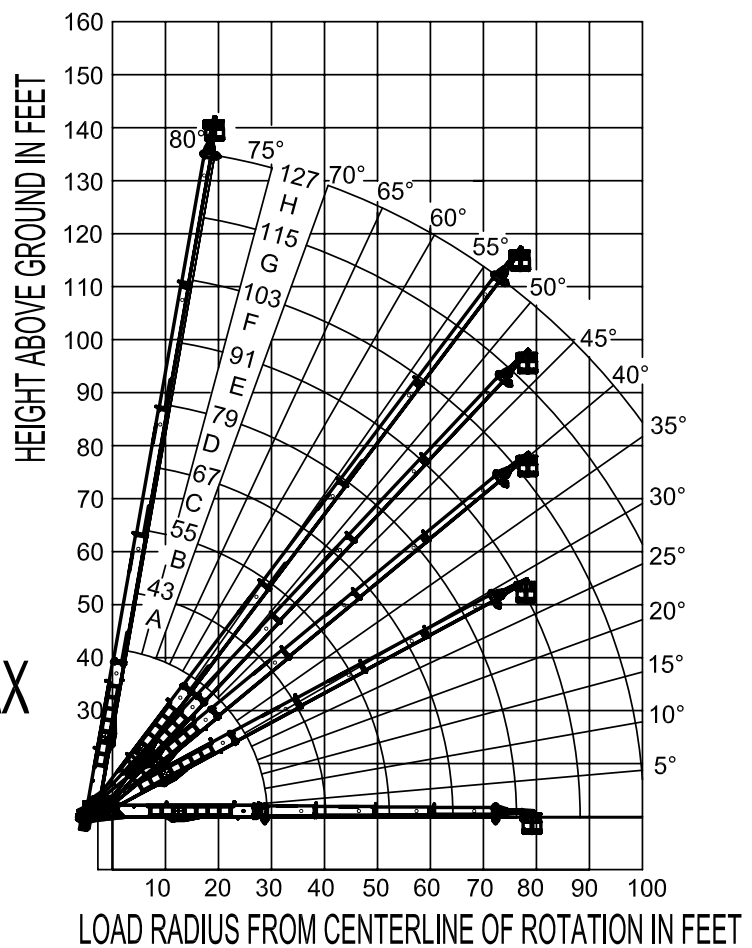

PERSONNEL 1200LBS MAX

**USE OUTRIGGERS
AT ALL TIMES**

- NOTE:
1. Personnel handling is allowed only with full span outriggers.
 2. Boom load ratings are based on loaded boom radius.
Loaded boom angles are given as reference only.

CRANE MEETS ASME B30.5 REQUIREMENTS AT TIME OF MANUFACTURE

DO NOT PAINT OVER ANY LABELS

1181460 092012



Elliott Equipment Company
4427 South 76th Circle
Omaha, NE 68127
Phone: 402-592-4500
Fax: 402-592-4553
Email: sales@elliottequip.com

Built for You.
www.elliottequip.com

MAIN BOOM WINCH DATA



MODEL 4500

127-ft BOOM

PARTS OF LINE

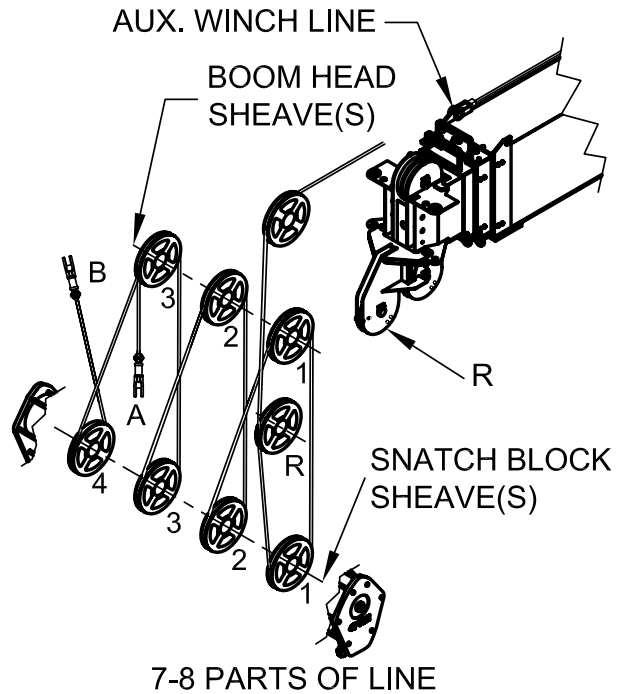
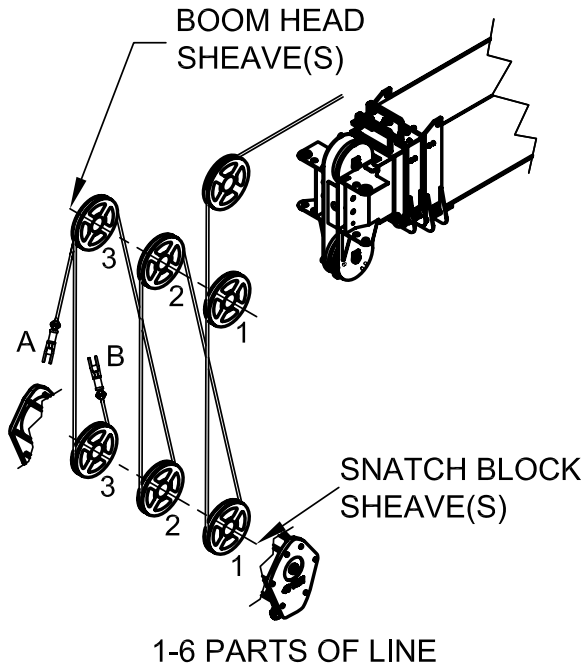

NOTICE:

- DO NOT DEADHEAD LINE BLOCK AGAINST BOOM TIP WHEN EXTENDING BOOM.
- KEEP AT LEAST 5 WRAPS OF LOADLINE ON THE WINCH DRUM AT ALL TIMES.
- USE ONLY 5/8" DIAMETER WIRE ROPE, AS SPECIFIED, WITH THE PROPER BREAKING STRENGTH LISTED.
- ANTI-TWO-BLOCK SYSTEM MUST BE IN GOOD OPERATING CONDITION BEFORE OPERATING CRANE. SEE OPERATION & SAFETY MANUAL.

PARTS OF LINE	SHEAVE(S) ON BOOM HEAD	SHEAVE(S) ON SNATCH BLOCK	5/8" - SPIN RESISTANT (5:1 S.F.) 50,000-lbs. BREAKING STRENGTH
1	1	A	10,000 lbs
2	1B	1	20,000 lbs
3	12	1A	30,000 lbs
4	12B	12	40,000 lbs
5	123	12A	50,000 lbs
6	123B	123	60,000 lbs
7	R123	123A	70,000 lbs
8	R123B	1234	80,000 lbs

A-DEAD END FOR ODD PARTS OF LINE
 B-DEAD END FOR EVEN PARTS OF LINE
 R-ROOSTER SHEAVE REQUIRED WHEN USING 7 AND 8 PARTS OF LINE

CRANE MEETS ASME B30.5 REQUIREMENTS AT TIME OF MANUFACTURE

DO NOT PAINT OVER ANY LABELS

1181460 092012



Elliott Equipment Company
 4427 South 76th Circle
 Omaha, NE 68127
 Phone: 402-592-4500
 Fax: 402-592-4553
 Email: sales@elliottequip.com

Built for You.
www.elliottequip.com

TRUCK CHASSIS SPECIFICATIONS

	45127 BoomTruck
Wheelbase (WB)	297" / 754 cm
Cab to Axle (CT)	204" / 518 cm
Frame Section Modulus	30.0 in3-110,000 psi / 758 428 kPa
Front Axle Gross Weight Rating	20,000 lb / 9072 kg
Rear Axle Gross Weight Rating	66,000 lb / 29 937 kg
Pusher Axle Rating	8,000 lb / 3629 kg
Integral Front Frame Extensions	Required for Optional Front Stabilizer

Chassis data is minimum general requirements-not for engineering.
 Actual dimensions and truck data will depend on truck selection and axle configuration.
 *Minimum chassis weight is required to meet 85% stability requirements.

OPTIONS



Radio Remote Control

Interference protected radio remotes let you get closer to your work and have full control over your machine. Optional LMI display is available.



Bridge-Legal in All 50 States

In partnership with chassis manufacturers, Elliott Equipment is proud to offer a bridge-legal version of the 45127 in all 50 US states. Contact us to learn more.



Air Conditioning in Crane Cab

Work all day in comfort with an high efficiency air conditioning system mounted on the rear of the crane control cab.



Dual Winch System & Drum Indicators

Take advantage of Elliott's auxiliary dual 10,000 lb single line pull winch package with optional winch drum rotation indicators



Tool Boxes

Optional tool boxes and bed storage can accommodate any storage need for tools, work materials and more.

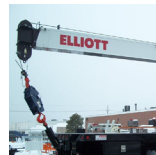

Hook Block for Multi-Part Line

Elliott can include a hook block device for up to 8 parts of line to improve lifting capabilities and allow you to maximize your use of the crane.



2-Man Yoke Work Platform

Elliott's new 1,200 lb capacity 2-man platform features a hydraulic yoke lifting system for easy attachment to the boom tip. Fully OSHA compliant and heavy duty.



Body Mounted Hose Reels and Circuits

Let us work with you to customize your tool compatability by adding hose reels or hydraulic circuits to the crane bed.



45142 SIDE VIEW DIAGRAM

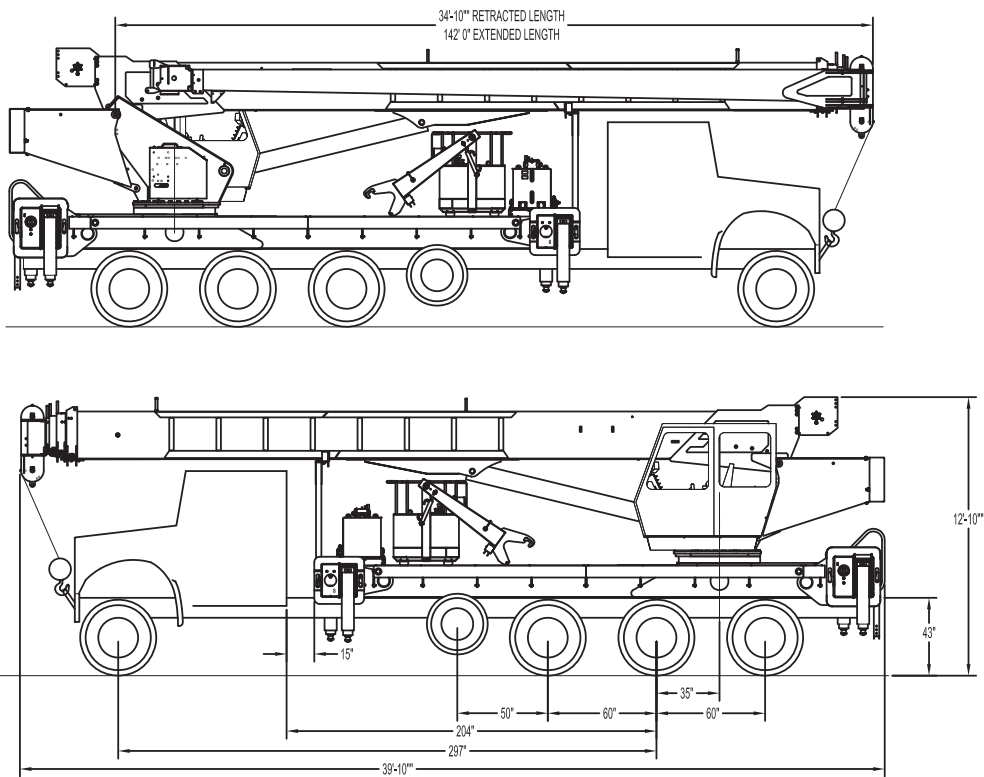

- | | | | |
|----------------------------------|----------------------|---------------------------------|--------------------------------|
| • Maximum Vertical Reach | 207'63,1 m | • Powered Boom Sections | 5 |
| • Working Area | 360 Degrees | • Overall Height | 12'10"/3,9 m |
| • Lifting Capacity | 90,000 lbs/40 823 kg | • Operator Controls | Rotating Cab with Control Seat |
| • Boom Length | 142'43,3 m | • Outrigger Type Front | Out-Down |
| • Crane Weight (Standard) | 43,800 lbs/19 867 kg | • Outrigger Spread Front | 21'2"/6,4 m |
| • Jib Lengths | 32'-55' / 9,7-16,7 m | • Outrigger Type Rear | Out-Down |
| • Winch Bare Drum Pull | 15,000 lbs/6804 kg | • Outrigger Spread Rear | 26'2"/8 m |

TECHNICAL SPECIFICATIONS

Crane Capacity: 90,000 lbs at 7' radius.

Maximum Tip Height: 152' tip height (207' with 55' jib).

Control Console: Rotating seated controls with operator cab and deluxe operators seat. Station equipped with four pilot operated control levers for the main crane controls. Operator station includes LMI display, diesel heater, bubble level gauge, engine start/stop switch, signal horn button, variable speed throttle switch, lifting capacity chart, range diagram chart, boom angle indicator, system pressure gauge, 12V DC power source, and cup holder. Independent ground level electric operated outrigger controls.

Boom: Five-section fully proportional, high strength steel plated rectangular tube sections. 34'10" retracted to 142' extended boom. A maximum tip height of 152' mounted on a truck. The boom nose contains one floating upper sheave and three lower sheaves. Assembly includes heavy-duty cylinder fittings, pivot pins, and replaceable wear pads.

Winch: Mounted at the base of the boom for a long fleet angle and flat level spooling of cable. Winch is driven by a planetary reducer and powered by a hydraulic motor. Burst-of-speed winch provides increased line speed. The winch brake is spring applied, pressure release design. Supplied with 430' of 5/8" diameter rotation resistant wire rope with a single line pull of 11,300 lbs. or 12,500 lbs depending on rope type, and a downhaul ball with swivel hook for single part line.

Load Moment Indicator System: System senses hoist cylinder pressures, boom length and boom angle with hydraulic function lockout. The display console is equipped with a bar graph showing crane utilization, boom angle or boom length, a mode select controls for main boom and jib operation, and an anti-two block with an audio/visual warning and shut-off functions to limit

Elliott Equipment Company reserves the right to change the specification of any unit at any time without prior notice. This brochure is only a statement of general specifications on the date of this publication. For more detailed info on specific Elliott trucks go to www.elliottequip.com

hook-boom point contact.

Outriggers: Two sets of out and down overframe outriggers. Front outriggers have a 21'2" span, rear outriggers have a 26'2" span. Outriggers are configured for full span or mid span operation. Outriggers equipped with 22" diameter ball socket aluminum removable pads that stow on vertical outrigger legs.

Frame: Full length, all welded rigid 4-plate design sub-frame. Sub-frame allows for bolt-on addition of aluminum bed wings, with top plate of subbase serving as a portion of the bed deck, to form a three-piece bed.

Turret: Reverse offset turret is one-piece weldment. Turret rotates on large diameter ball bearing.

Rotation: Hydraulic motor drives turret through double reduction planetary swing drive for 360 degree continuous rotation. Glide-swing drive system has manual foot applied brake

Lift: One double-acting long stroke cylinder provides smooth and stable boom elevation. Holding valve prevents boom from falling in event of hose failure.

Boom Extension: Incorporates a 2-stage hydraulic extension cylinder, attached to the largest boom section, with a proportional cable extension system driving the outermost sections.

Hoses: All high pressure hoses are wire braid reinforced with a minimum safety factor of 4 to 1.

Cylinders: All cylinders use microhoned cylinder tubing, chrome shafts, top grade packing and protective rod wipers. Cylinder-mounted holding valves provided on all load-holding cylinders.

Hydraulic System: Equipped with air-shift PTO, piston pump, SAE O-ring face seals on pressure lines, and a 10-micron return line filter. Hydraulic oil cooler. The control valve distributes all flow to hoist system, swing circuit, and

other crane functions. System is closed center type.

Oil Tank Capacity: 119 gallons mounted to top of frame.

Cab Equipment: Air shift PTO with indicator lights installed in truck cab. U/L approved 5:BC dry chemical fire extinguisher installed in truck cab.

Operators Manual & Video: Two CD copies and one hard copy of operation, maintenance, safety and parts manual provided with each unit. Operational and safety video provided at delivery.

Installation: Unit installed on chassis, painted, system and tank filled with oil, tested, inspected, and ready to operate.

Standard Paint: Paint turret and boom white, outriggers red, and bed and boxes black.

Bumper: Bureau of Motor Carrier Safety rear bumper.

Weight: Approximately 43,800 lbs. less truck.

Truck Chassis Required: Approx. 204" C.T., RBM 3,300,000 in-lb. per rail, 20,000 lb. front axle, 66,000 lb. tridem rear axles, and 8,000 lb pusher axle recommended. 94,000 lb. GVWR. Additional configurations available for bridge legal cranes and export. Contact factory when additional equipment is to be added.

Options:

Air Conditioning for Crane Cab.

32'-55' 2-Stage Telescopic Jib.

50-State Federal Bridge Legal Mounting.

Gravity Leveled Work Platform.

Wireless Radio Remote Controls.

Winch Drum Rotation Indicator.

Auxiliary Winch Package.

Work Area Definition (WADS)

Much More...

LOAD CHART - FULL SPAN OUTRIGGERS



MODEL 4500 142-ft BOOM

MAIN BOOM LOAD RATINGS WITH FULLY EXTENDED OUTRIGGERS

LMI MODE: NONE

MAIN BOOM LOAD RATINGS

LOAD RATINGS IN lbs WITH OUTRIGGERS AND STABILIZERS EXTENDED

LOAD RADIUS IN FEET	LOADED BOOM ANGLE	34-ft	LOADED BOOM ANGLE	A 47-ft	LOADED BOOM ANGLE	B 61-ft	LOADED BOOM ANGLE	C 74-ft	LOADED BOOM ANGLE	D 88-ft	LOADED BOOM ANGLE	E 101-ft	LOADED BOOM ANGLE	F 115-ft	LOADED BOOM ANGLE	G 128-ft	LOADED BOOM ANGLE	H 142-ft	
7	75.4	90,000																	
8	73.2	80,000																	
10	71.0	66,500	76.7	43,000															
12	67.3	56,100	74.3	43,000	79.1	43,000													
15	61.7	49,000	70.5	43,000	76.3	42,400	79.5	36,600											
20	50.9	38,000	63.6	34,000	71.4	34,000	75.7	31,700	78.7	24,900									
25	38.1	27,600	56.0	27,900	66.3	28,200	71.5	26,400	75.2	21,000	77.8	17,500							
30	19.3	20,450	47.8	20,950	60.6	21,200	67.2	21,450	71.7	18,400	75.0	16,000	77.5	13,400	79.3	11,500			
35			38.0	16,250	54.5	16,500	62.8	16,750	68.1	16,000	72.0	14,400	75.0	11,800	77.0	10,100	79.1	6,600	
40			25.2	12,900	48.0	13,250	58.0	13,450	64.4	13,450	68.8	12,600	72.2	10,700	74.9	8,900	77.0	6,600	
45					40.7	10,850	52.9	11,050	60.6	11,150	65.6	11,250	69.8	9,400	72.6	8,100	74.8	6,600	
50					31.9	8,900	47.3	9,100	56.5	9,200	62.3	9,300	67.0	8,400	70.1	7,400	72.7	5,900	
55					19.8	7,500	41.2	7,600	52.3	7,700	59.1	7,800	64.2	7,500	67.6	6,500	70.5	5,300	
60							34.9	6,300	48.0	6,400	55.5	6,500	61.2	6,700	65.0	5,900	68.3	4,800	
65							26.4	5,200	43.0	5,300	51.8	5,500	58.1	5,500	62.4	5,300	65.9	4,300	
70							12.9	4,250	37.3	4,400	47.6	4,550	55.0	4,550	59.7	4,550	63.6	3,900	
75									30.8	3,600	43.1	3,700	54.6	3,700	56.9	3,800	61.2	3,500	
80									22.5	2,850	38.2	2,950	47.8	3,050	54.0	3,050	58.7	3,100	
85											32.7	2,350	43.8	2,450	50.8	2,600	56.2	2,600	
90											26.1	1,800	39.6	1,950	47.4	2,050	53.5	2,050	
95											17.1	1,350	34.9	1,550	43.8	1,650	50.7	1,650	
100													29.6	1,100	40.0	1,200	47.6	1,250	
105													23.1	450	35.8	950	44.3	950	
110															31.6	450	41.0	450	
0		17,000	0	10,600	0	6,600	0	4,500	0	2,500	0	1,300							
DEDUCTIONS FOR STOWED EXTENDABLE JIB (lbs)		950		700		550		450		400		350		300		250		200	DEDUCTIONS FOR STOWED EXTENDABLE JIB (lbs)

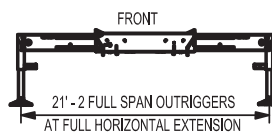
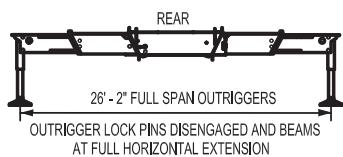

ELLIOTT EQUIPMENT CO. SUPPLIED LOADLINE EQUIPMENT DEDUCTIONS:

- DOWNHAUL WEIGHT.....210 lbs
- ONE SHEAVE BLOCK.....559 lbs
- TWO SHEAVE BLOCK.....643 lbs
- THREE SHEAVE BLOCK.....695 lbs
- FOUR SHEAVE BLOCK.....762 lbs
- AUXILIARY SHEAVE.....100 lbs

CRANE MEETS ASME B30.5 REQUIREMENTS AT TIME OF MANUFACTURE

DO NOT PAINT OVER ANY LABELS 1190860 060613



Elliott Equipment Company Phone: 402-592-4500
 4427 South 76th Circle Fax: 402-592-4553
 Omaha, NE 68127 Email: sales@elliottequip.com

Built for You.
www.elliottequip.com

LOAD CHART - MID-SPAN OUTRIGGERS



MODEL 4500

142-ft BOOM

MAIN BOOM LOAD RATINGS WITH MIDSPAN OUTRIGGERS

LMI MODE: NONE

LOAD RATINGS IN lbs WITH OUTRIGGERS AND STABILIZERS EXTENDED

LOAD RADIUS IN FEET	LOADED BOOM ANGLE	34-ft	A	47-ft	BOOM ANGLE	B	61-ft	BOOM ANGLE	C	74-ft	BOOM ANGLE	D	88-ft	BOOM ANGLE	E	101-ft	BOOM ANGLE	F	115-ft	BOOM ANGLE	G	128-ft	BOOM ANGLE	H	142-ft
7	75.4	90,000																							
8	73.2	80,000																							
10	71.0	66,500	76.7	43,000																					
12	67.3	56,100	74.3	43,000	79.1	43,000																			
15	61.7	49,000	70.5	43,000	76.3	42,400	79.5	36,600																	
20	50.9	38,000	63.6	34,000	71.4	34,000	75.7	31,700	78.7	24,900															
25	38.1	23,500	56.0	24,000	66.3	25,000	71.5	25,000	75.2	21,000	77.8	17,500													
30	19.3	16,000	47.8	16,000	60.6	16,000	67.2	16,000	71.7	18,400	75.0	16,000	77.5	13,400	79.3	11,500									
35			38.0	12,000	54.5	12,000	62.8	13,300	68.1	14,000	72.0	14,400	75.0	11,800	77.0	10,100	79.1	6,600							
40			25.2	9,700	48.0	10,000	58.0	10,500	64.4	11,000	68.8	11,000	72.2	10,700	74.9	8,900	77.0	6,600							
45					40.7	8,000	52.9	8,400	60.6	8,400	65.6	8,500	69.8	8,500	72.6	8,000	74.8	6,600							
50					31.9	6,500	47.3	6,800	56.5	6,900	62.3	6,900	67.0	7,000	70.1	7,000	72.7	5,900							
55					19.8	5,100	41.2	5,300	52.3	5,400	59.1	5,500	64.2	5,600	67.6	5,700	70.5	5,000							
60							34.9	4,200	48.0	4,300	55.5	4,400	61.2	4,400	65.0	4,500	68.3	4,500							
65							26.4	3,300	43.0	3,400	51.8	3,500	58.1	3,500	62.4	3,600	65.9	3,600							
70							12.9	2,500	37.3	2,600	47.6	2,700	55.0	2,800	59.7	2,900	63.6	2,900							
75									30.8	1,900	43.1	2,000	54.6	2,100	56.9	2,200	61.2	2,200							
80									22.5	1,300	38.2	1,300	47.8	1,400	54.0	1,400	58.7	1,500							
85											32.7	1,000	43.8	1,000	50.8	1,000	56.2	1,000							
0		15,000	0	8,000	0	4,000	0	1,000																	
DEDUCTIONS FOR STOWED EXTENDABLE JIB (lbs)		950		700		550		450		400		350		300		250		200							DEDUCTIONS FOR STOWED EXTENDABLE JIB (lbs)

NOTE:

- Operate jib by radius when main boom is fully extended. Increase boom angle if necessary to maintain load radius.
- When boom is retracted, operate jib by boom angles. Do not exceed any rated jib capacities at reduced boom lengths.
- Do not exceed capacities recommended by ASME/ANSI B30.5.
- Load ratings above bold line are structurally limited.
- Personnel handling is allowed only with full span outriggers.
- Boom load ratings are based on loaded boom radius. Loaded boom angles are given as reference only.

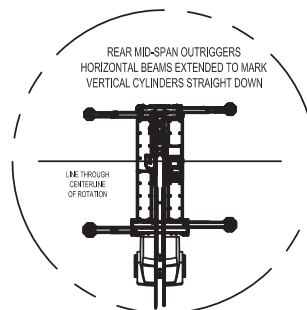

ELLIOTT EQUIPMENT CO. SUPPLIED LOADLINE EQUIPMENT DEDUCTIONS:

- DOWNHAUL WEIGHT.....210 lbs
- ONE SHEAVE BLOCK.....559 lbs
- TWO SHEAVE BLOCK.....643 lbs
- THREE SHEAVE BLOCK.....695 lbs
- FOUR SHEAVE BLOCK.....762 lbs
- AUXILIARY SHEAVE.....100 lbs

CRANE MEETS ASME B30.5 REQUIREMENTS AT TIME OF MANUFACTURE

DO NOT PAINT OVER ANY LABELS

1190860 060613



Elliott Equipment Company
4427 South 76th Circle
Omaha, NE 68127
Phone: 402-592-4500
Fax: 402-592-4553
Email: sales@elliottequip.com

Built for You.
www.elliottequip.com

RANGE CHART - FULL SPAN OUTRIGGERS



MODEL 4500 142-ft BOOM

RANGE DIAGRAM WITH FULLY EXTENDED OUTRIGGERS

LMI MODE: NONE

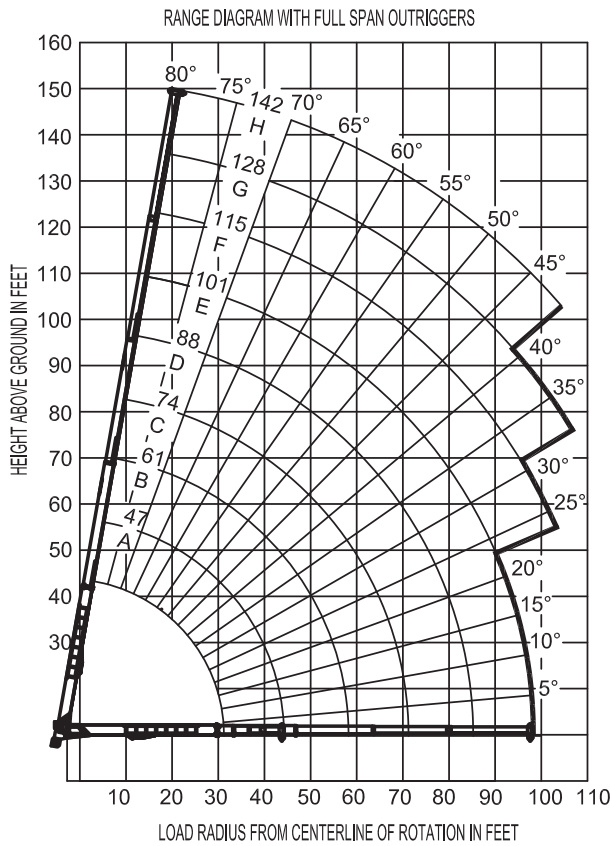

NOTE:

1. Operate jib by radius when main boom is fully extended. Increase boom angle if necessary to maintain load radius.
2. When boom is retracted, operate jib by boom angles. Do not exceed any rated jib capacities at reduced boom lengths.
3. Capacities do not exceed 85% stability.
4. Load ratings above bold line are structurally limited.
5. Personnel handling is allowed only with full span outriggers.
6. Boom load ratings are based on loaded boom radius. Loaded boom angles are given as reference only.

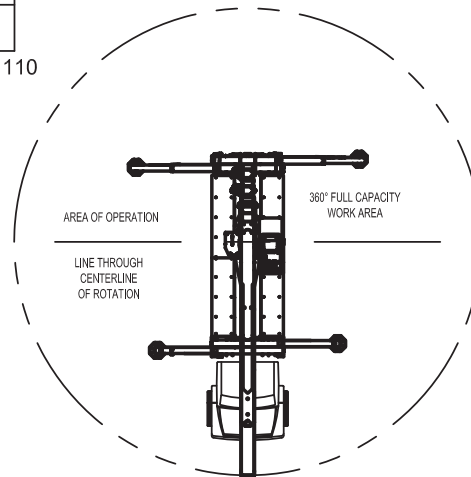
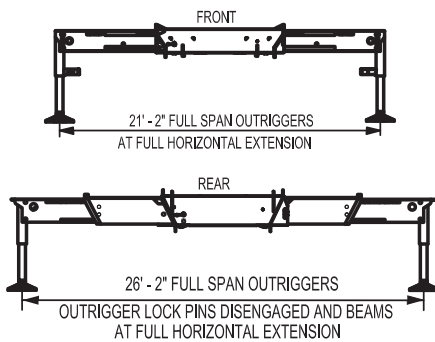

CRANE MEETS ASME B30.5 REQUIREMENTS AT TIME OF MANUFACTURE

DO NOT PAINT OVER ANY LABELS 1190860 060613

JIB CHART - FULL-SPAN OUTRIGGERS, 32'-55' TWO SECTION JIB



MODEL 4500

142-ft BOOM

JIB LOAD RATINGS WITH FULLY EXTENDED OUTRIGGERS

LMI MODE: 31'RET & 55'EXT

31'-55' TWO SECTION JIB

LOAD RADIUS IN FEET	LOADED BOOM ANGLE	31-ft JIB 360°	LOAD RADIUS IN FEET	LOADED BOOM ANGLE	55-ft JIB 360°
33	80	3,600	40	80	2,400
50	75	3,600	59	75	2,400
65	70	1,200	76	70	800
LMI MODE: 31'RET			LMI MODE: 55'EXT		

DO NOT OPERATE JIB IN WINDS EXCEEDING 15MPH

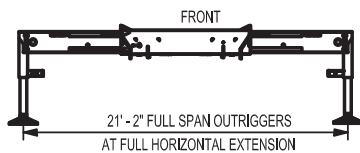
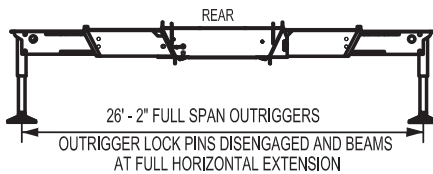

NOTE:

1. Operate jib by radius when main boom is fully extended. Increase boom angle if necessary to maintain load radius.
2. When boom is retracted, operate jib by boom angles. Do not exceed any rated jib capacities at reduced boom lengths.
3. Do not exceed capacities recommended by ASME/ANSI B30.5.
4. Load ratings above bold line are structurally limited.
5. Personnel handling is allowed only with full span outriggers.
6. Boom load ratings are based on loaded boom radius. Loaded boom angles are given as reference only.

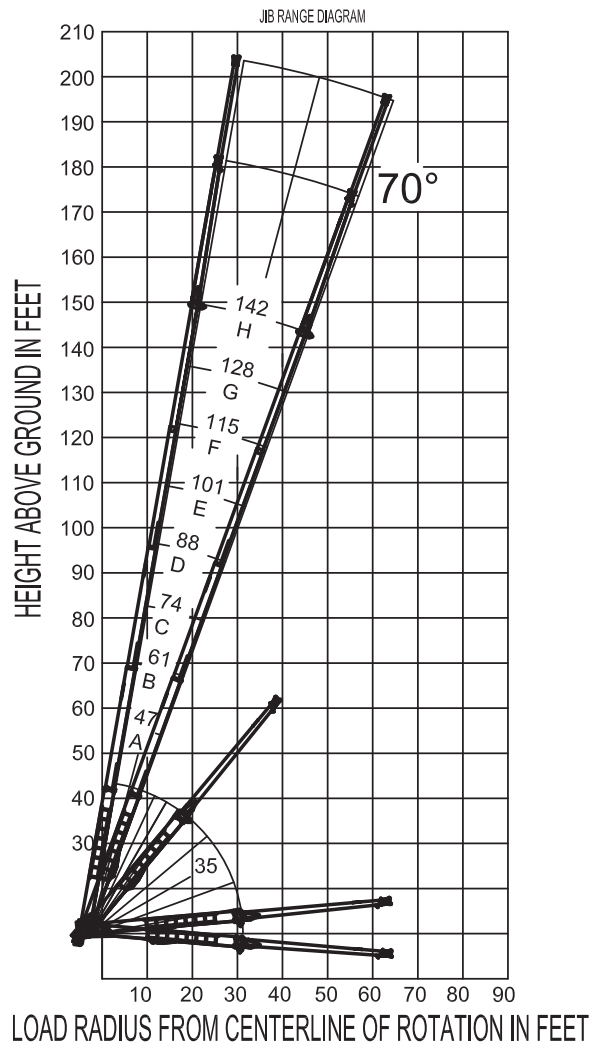

CRANE MEETS ASME B30.5 REQUIREMENTS AT TIME OF MANUFACTURE

DO NOT PAINT OVER ANY LABELS

1190860 060613

RANGE CHART - JIB & 2-MAN BASKET 600 LB / 272 KG CAPACITY



MODEL 4500

142-ft BOOM

2 PIECE FULLY EXTENDED JIB RANGE DIAGRAM WITH PLATFORM ATTACHED

LMI MODE: BSKT1_55'

PERSONNEL 600LBS MAX
DO NOT OPERATE JIB IN WINDS EXCEEDING 15MPH
USE OUTRIGGERS AT ALL TIMES

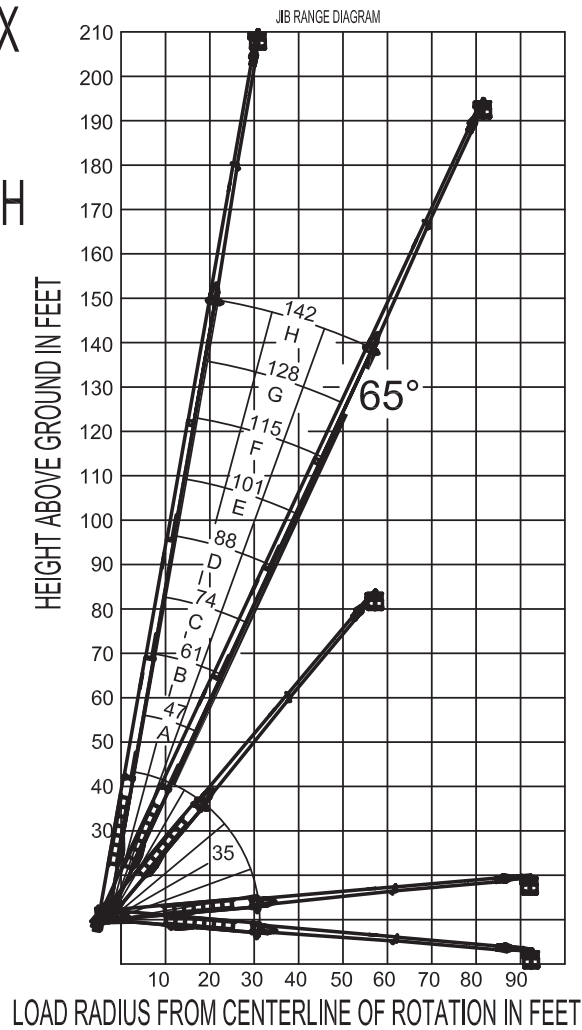

NOTE:

1. Operate jib by radius when main boom is fully extended. Increase boom angle if necessary to maintain load radius.
2. When boom is retracted, operate jib by boom angles. Do not exceed any rated jib capacities at reduced boom lengths.
3. Do not exceed capacities recommended by ASME/ANSI B30.5.
4. Load ratings above bold line are structurally limited.
5. Personnel handling is allowed only with full span outriggers.
6. Boom load ratings are based on loaded boom radius. Loaded boom angles are given as reference only.

CRANE MEETS ASME B30.5 REQUIREMENTS AT TIME OF MANUFACTURE

DO NOT PAINT OVER ANY LABELS

1190860 060613



Elliott Equipment Company
 4427 South 76th Circle
 Omaha, NE 68127
 Phone: 402-592-4500
 Fax: 402-592-4553
 Email: sales@elliottequip.com

Built for You.
www.elliottequip.com

RANGE CHART - JIB & 2-MAN BASKET 1,200 LB / 544 KG CAPACITY



MODEL 4500

142-ft BOOM

2 PIECE FULLY EXTENDED JIB RANGE DIAGRAM WITH PLATFORM ATTACHED

LMI MODE: BSKT2_55'

PERSONNEL 1200LBS MAX

DO NOT OPERATE JIB IN WINDS EXCEEDING 15MPH

USE OUTRIGGERS AT ALL TIMES

NOTE:

1. Operate jib by radius when main boom is fully extended.
Increase boom angle if necessary to maintain load radius.
2. When boom is retracted, operate jib by boom angles.
Do not exceed any rated jib capacities at reduced boom lengths.
3. Do not exceed capacities recommended by ASME/ANSI B30.5.
4. Load ratings above bold line are structurally limited.
5. Personnel handling is allowed only with full span outriggers.
6. Boom load ratings are based on loaded boom radius.
Loaded boom angles are given as reference only.

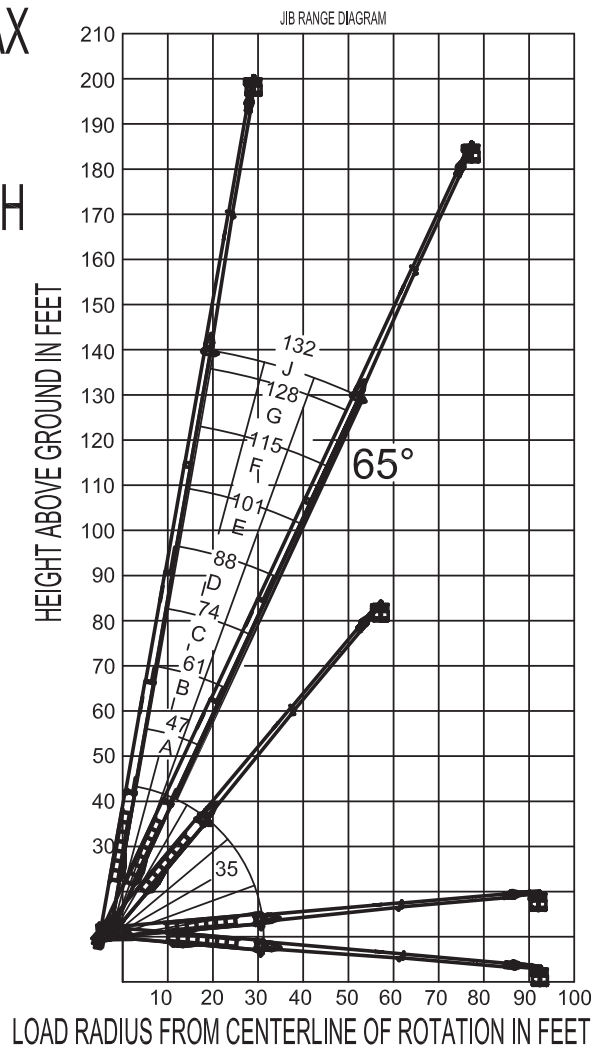

CRANE MEETS ASME B30.5 REQUIREMENTS AT TIME OF MANUFACTURE

DO NOT PAINT OVER ANY LABELS

1190860 060613



Elliott Equipment Company
4427 South 76th Circle
Omaha, NE 68127
Phone: 402-592-4500
Fax: 402-592-4553
Email: sales@elliottequip.com

Built for You.
www.elliottequip.com

MAIN BOOM WINCH DATA



MODEL 4500

142-ft BOOM

PARTS OF LINE

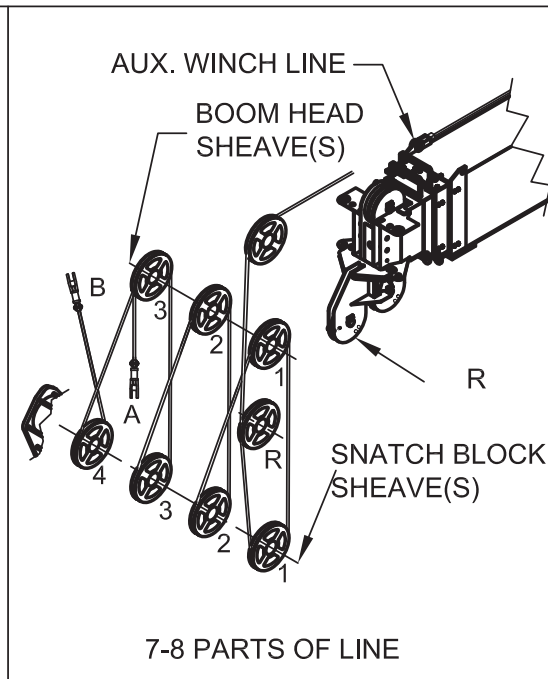
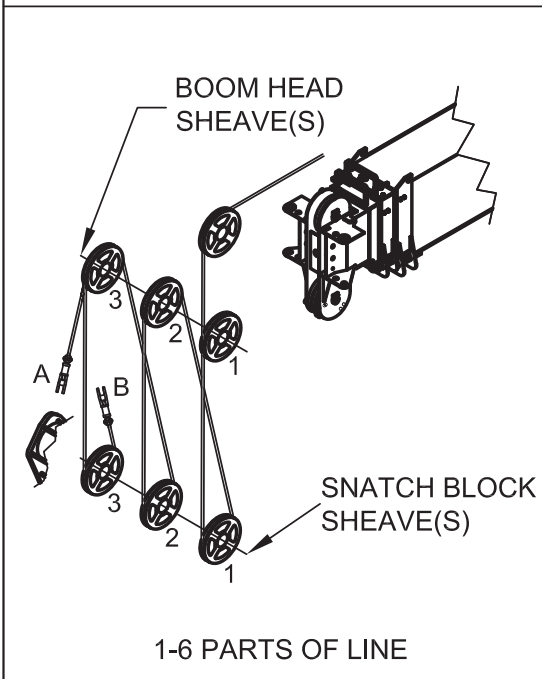

NOTICE:

- DO NOT DEADHEAD LINE BLOCK AGAINST BOOM TIP WHEN EXTENDING BOOM.
- KEEP AT LEAST 5 WRAPS OF LOADLINE ON THE WINCH DRUM AT ALL TIMES.
- USE ONLY 5/8" DIAMETER WIRE ROPE, AS SPECIFIED, WITH THE PROPER BREAKING STRENGTH LISTED.
- ANTI-TWO-BLOCK SYSTEM MUST BE IN GOOD OPERATING CONDITION BEFORE OPERATING CRANE. SEE OPERATION & SAFETY MANUAL.

PARTS OF LINE	SHEAVE(S) ON BOOM HEAD	SHEAVE(S) ON SNATCH BLOCK	5/8" - SPIN RESISTANT (5:1 S.F.) 56,500-lbs. BREAKING STRENGTH	5/8" - 6X36 IWRC (3.5:1 S.F.) 45,400-lbs. BREAKING STRENGTH
1	1	A	11,300 lbs	12,500 lbs
2	1 B	1	22,600 lbs	25,000 lbs
3	1 2	1 A	33,900 lbs	37,500 lbs
4	1 2 B	1 2	45,200 lbs	50,000 lbs
5	1 2 3	1 2 A	56,500 lbs	62,500 lbs
6	1 2 3 B	1 2 3	67,800 lbs	75,000 lbs
7	R 1 2 3	1 2 3 A	79,100 lbs	87,500 lbs
8	R 1 2 3 B	1 2 3 4	90,000 lbs	90,000 lbs

A-DEAD END FOR ODD PARTS OF LINE
 B-DEAD END FOR EVEN PARTS OF LINE
 R-ROOSTER SHEAVE REQUIRED WHEN USING 7 AND 8 PARTS OF LINE

CRANE MEETS ASME B30.5 REQUIREMENTS AT TIME OF MANUFACTURE

DO NOT PAINT OVER ANY LABELS

1190860 060613



Elliott Equipment Company
 4427 South 76th Circle
 Omaha, NE 68127
 Phone: 402-592-4500
 Fax: 402-592-4553
 Email: sales@elliottequip.com

Built for You.
www.elliottequip.com

TRUCK CHASSIS SPECIFICATIONS

	45142 BoomTruck
Wheelbase (WB)	297" / 754 cm
Cab to Trunnion (CT)	204" / 518 cm
Frame Section Modulus	30.0 in ³ - 110,000 psi / 758 428 kPa
Front Axle Gross Weight Rating	20,000 lb / 9072 kg
Rear Axle Gross Weight Rating	66,000 lb / 31 298 kg
Pusher Axle Rating	8,000 lb / 3629 kg
Permit-Free Truck Configurations	Contact Factory for More Information

Chassis data is minimum general requirements-not for engineering.
 Actual dimensions and truck data will depend on truck selection and axle configuration.
 *Minimum chassis weight is required to meet 85% stability requirements.

OPTIONS



Radio Remote Control

Interference protected radio remotes let you get closer to your work and have full control over your machine. Optional LMI display is available.



Bridge-Legal in All 50 States

In partnership with chassis manufacturers, Elliott Equipment is proud to offer a federal bridge-legal version of the 45142 in all 50 US states. Contact us to learn more.



Air Conditioning in Crane Cab

Work all day in comfort with an high efficiency air conditioning system mounted on the rear of the crane control cab.



Dual Winch System & Drum Indicators

Take advantage of Elliott's auxiliary dual 10,000 lb single line pull winch package with optional winch drum rotation indicators.



Tool Boxes

Optional tool boxes and bed storage can accommodate any storage need for tools, work materials and more.

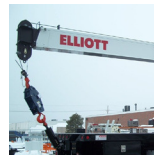

Hook Block for Multi-Part Line

Elliott can include a hook block for up to 8 parts of line to improve lifting capabilities and allow you to maximize your use of the crane.



2-Man Yoke Work Platform

Elliott's new 1,200 lb capacity 2-man platform features a hydraulic yoke lifting system for easy attachment to the boom tip. Fully OSHA compliant and heavy duty.



Body Mounted Hose Reels and Circuits

Let us work with you to customize your tool compatability by adding hose reels or hydraulic circuits to the crane bed.



50105R SIDE VIEW DIAGRAM

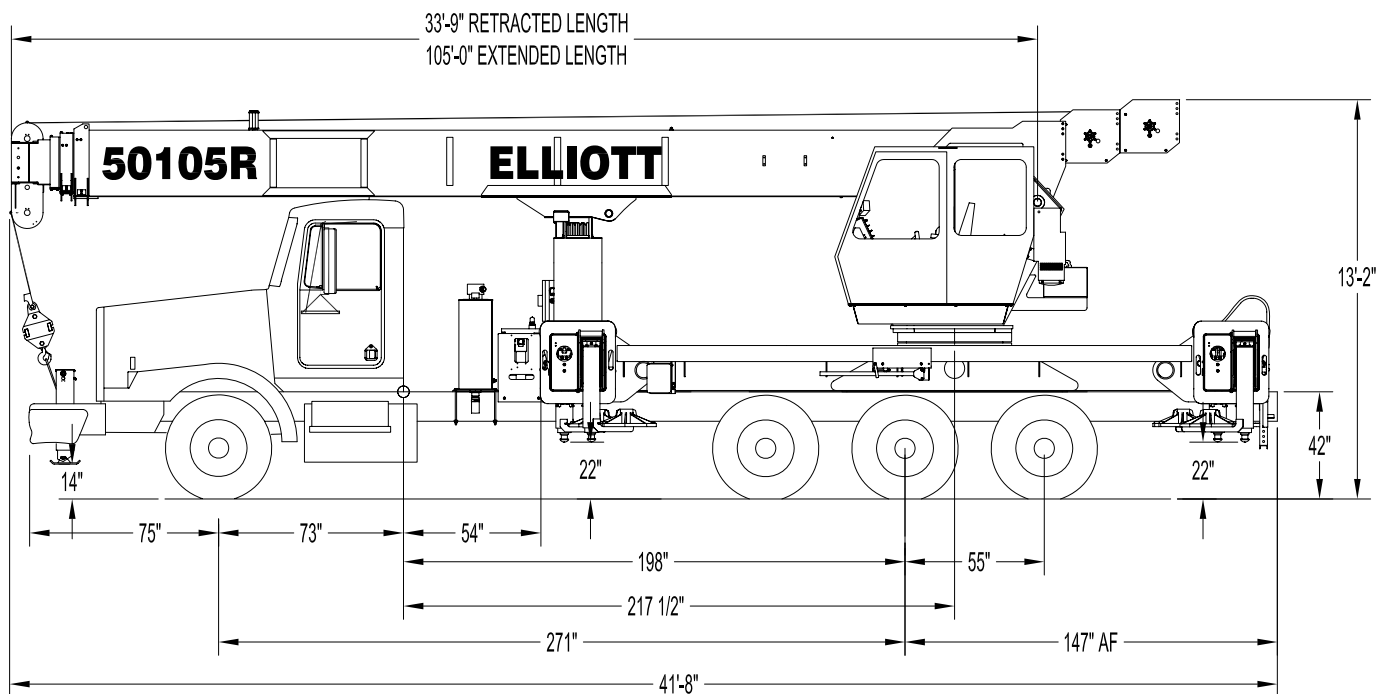

- | | | | |
|----------------------------------|-----------------------|---------------------------------|--------------------------|
| • Maximum Vertical Reach | 164'/50 m | • Powered Boom Sections | 4 |
| • Working Area | 360 Degrees | • Overall Height | 13'2"/4 m |
| • Lifting Capacity | 100,000 lbs/45,359 kg | • Operator Controls | Rotating Seated With Cab |
| • Boom Length | 105'/32 m | • Outrigger Type Front | Out-Down |
| • Crane Weight (Standard) | 38,200 lbs/17,327 kg | • Outrigger Spread Front | 26'2"/8 m |
| • Jib Lengths | 32', 49'/ 9.8 m, 15 m | • Outrigger Type Rear | Out-Down |
| • Winch Bare Drum Pull | 15,000 lbs/6,804 kg | • Outrigger Spread Rear | 26'2"/8 m |

TECHNICAL SPECIFICATIONS

Crane Capacity: 100,000 lbs at nine feet load radius.

Maximum Tip Height: 115' height (164' with optional 49' jib)

Control Console: Rotating seated controls with operator cab and deluxe operators seat. Station equipped with four pilot operated control levers for the main crane controls. Operator station includes LMI display, diesel heater, bubble level gauge, engine start/stop switch, signal horn button, variable speed throttle switch, lifting capacity chart, range diagram chart, boom angle indicator, system pressure gauge, 12V DC power source, and cup holder. Independent ground level electric operated outrigger controls.

Boom: Four-section fully proportional, high strength steel plated rectangular tube sections. A maximum boom tip height of 164' mounted on a truck. The boom nose contains one floating upper sheave and three lower sheaves. Assembly includes heavy-duty cylinder fittings, pivot pins, and replaceable wear pads.

Winch: Mounted at the base of the boom for a long fleet angle and flat level spooling of cable. Winch is driven by a planetary reducer and powered by a hydraulic motor. Burst-of-speed winch provides increased line speed. The winch brake is spring applied, pressure release design. Supplied with 430' of 5/8" diameter rotation resistant wire rope with a single line pull of 10,000 pounds, and a downhaul ball with swivel hook for single part line.

Load Moment Indicator System: System senses hoist cylinder pressures, boom length and boom angle with hydraulic function lockout. The display console is equipped with a bar graph showing crane utilization, boom angle or boom length, a mode select controls for main boom and jib operation, and an anti-two block with an audio/visual warning and shut-off functions to limit

Elliott Equipment Company reserves the right to change the specification of any unit at any time without prior notice. This brochure is only a statement of general specifications on the date of this publication. For more detailed info on specific Elliott trucks go to www.elliottequip.com

hook-boom point contact.

Outriggers: Two sets of out and down overframe outriggers with 26'2" span. Outriggers are configured for full span, mid span, and full retracted operation. Outriggers equipped with 22" diameter ball socket aluminum removable pads that stow on vertical outrigger legs. Front bumper stabilizer required.

Frame: Full length, all welded rigid 4-plate design sub-frame. Sub-frame allows for bolt-on addition of aluminum bed wings, with top plate of subbase serving as a portion of the bed deck, to form a three-piece bed.

Turret: Reverse offset turret is one-piece weldment. Turret rotates on large diameter ball bearing.

Rotation: Hydraulic motor drives turret through double reduction planetary swing drive for 360 degree continuous rotation. Glide-swing drive system has manual foot applied brake.

Lift: One double-acting long stroke cylinder provides smooth and stable boom elevation. Holding valve prevents boom from falling in event of hose failure.

Boom Extension: Incorporates a 2-stage hydraulic extension cylinder, attached to the largest boom section, with a proportional cable extension system driving the outermost sections.

Hoses: All high pressure hoses are wire braid reinforced with a minimum safety factor of 4 to 1.

Cylinders: All cylinders use microhoned cylinder tubing, chrome shafts, top grade packing and protective rod wipers. Cylinder-mounted holding valves provided on all load-holding cylinders.

Hydraulic System: Equipped with air-shift PTO, piston pump, SAE O-ring face seals on pressure lines, and a 10-micron return line filter. The control valve distributes all flow to hoist system, swing circuit, and other crane functions.

System is closed center type.

Oil Tank Capacity: 143 gallon mounted on top of truck frame.

Cab Equipment: Air shift PTO with indicator lights installed in truck cab. U/L approved 5:BC dry chemical fire extinguisher installed in truck cab.

Operators Manual & Video: Two CD copies and one hard copy of operation, maintenance, safety and parts manual provided with each unit. Operational and safety video provided at delivery.

Installation: Unit installed on chassis, painted, system and tank filled with oil, tested, inspected, and ready to operate.

Standard Paint: Paint turret and boom white, outriggers red, and bed and boxes black.

Bumper: Bureau of Motor Carrier Safety rear bumper.

Weight: Approximately 38,200 lbs. less truck.

Truck Chassis Required: Approx. 198" C.T., RBM 3,300,000 in-lb. per rail, 20,000 lb. front axle and 78,000 lb. GVWR required. Trucks must have front frame extension, 12V electrical system with high capacity alternator, cab clearance stop/tail/backup lights, and I.D. lamps. Recommended GVWR is minimum for BoomTruck with flatbed only. Contact factory when additional equipment is to be added.

Options:

Air Conditioning for Crane Cab.

49 ft. Telescopic Jib.

Gravity Leveled Work Basket.

Swing Counterweight up to 1,600 lbs.

Radio Remote Controls.

Auxiliary Winch for Faster Jib Deployment.

Much more...

LOAD CHART - MAIN BOOM, FULL-SPAN OUTRIGGERS



MODEL 5000 105-ft BOOM

MAIN BOOM LOAD RATINGS WITH FULLY EXTENDED OUTRIGGERS

MAIN BOOM LOAD RATINGS

LOAD RATINGS IN lbs WITH OUTRIGGERS AND STABILIZERS EXTENDED														
LOAD RADIUS IN FEET	LOADED BOOM ANGLE	33-ft	LOADED BOOM ANGLE	A 46-ft	LOADED BOOM ANGLE	B 57-ft	LOADED BOOM ANGLE	C 69-ft	LOADED BOOM ANGLE	D 81-ft	LOADED BOOM ANGLE	E 93-ft	LOADED BOOM ANGLE	F 105-ft
6	76.1	100,000												
9	72.6	80,000												
10	70.4	64,500	76.5	46,600										
12	66.4	58,100	73.9	46,600	77.9	46,600								
15	60.1	50,800	69.9	46,600	74.9	44,600	78.4	41,700						
20	48.5	39,700	62.7	38,900	69.3	36,500	74.0	34,900	77.2	30,700				
25	33.4	30,000	54.8	31,000	63.5	31,100	69.5	29,500	73.4	26,100	76.4	23,500	78.4	19,000
30			45.7	24,600	57.2	25,200	64.7	25,500	69.5	22,600	73.1	20,400	75.9	18,700
35			34.8	18,900	50.3	19,350	59.5	19,700	65.5	19,700	69.7	17,800	72.9	16,300
40			17.9	14,900	42.5	15,300	53.9	15,600	61.1	15,900	66.2	15,700	69.9	14,500
45					33.3	12,400	48.0	12,700	56.5	13,000	62.4	13,200	66.9	13,500
50					20.1	10,100	41.5	10,500	51.7	10,750	58.4	10,900	63.5	11,150
55							34.6	8,800	47.0	9,050	54.7	9,200	60.4	9,350
60							25.0	7,200	41.4	7,600	50.5	7,800	56.8	7,950
65									34.9	6,400	45.9	6,600	53.1	6,750
70									27.1	5,450	40.9	5,600	49.2	5,750
75									15.3	4,500	35.2	4,700	45.1	4,800
80											28.6	3,950	40.6	4,100
85											19.7	3,300	35.7	3,450
90													30.0	2,850
95													22.8	2,350
100													11.0	1,800
0		18,500	0	11,900	0	8,150	0	5,450	0	3,900	0	2,500	0	1,000

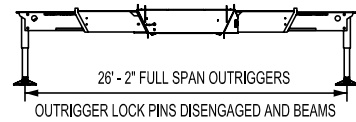

OUTRIGGER LOCK PINS DISENGAGED AND BEAMS AT FULL HORIZONTAL EXTENSION

- ELLIOTT EQUIPMENT CO. SUPPLIED LOADLINE EQUIPMENT DEDUCTIONS:
- DOWNHAUL WEIGHT225 lbs
 - ONE SHEAVE BLOCK.....424 lbs
 - TWO SHEAVE BLOCK.....592 lbs
 - THREE SHEAVE BLOCK.....639 lbs
 - FOUR SHEAVE BLOCK.....762 lbs
 - AUXILIARY SHEAVE.....100 lbs

DEDUCTIONS FOR STOWED JIB (lbs)	1,000	750	600	500	400	350	300	DEDUCTIONS FOR STOWED EXTENDABLE JIB (lbs)
DEDUCTIONS FOR STOWED FIXED LENGTH JIB (lbs)	650	500	400	350	250	200	200	DEDUCTIONS FOR STOWED FIXED LENGTH JIB (lbs)

CRANE MEETS ASME B30.5 REQUIREMENTS AT TIME OF MANUFACTURE

DO NOT PAINT OVER ANY LABELS 1141880 080708



Elliott Equipment Company
 4427 South 76th Circle
 Omaha, NE 68127
 Phone: 402-592-4500
 Fax: 402-592-4553
 Email: sales@elliottequip.com

Built for You.
www.elliottequip.com

LOAD CHART - MAIN BOOM, MID-SPAN OUTRIGGERS



MODEL 5000 105-ft BOOM

MAIN BOOM LOAD RATINGS WITH MIDSPAN OUTRIGGERS

LOAD RATINGS IN lbs WITH OUTRIGGERS AND STABILIZERS EXTENDED

LOAD RADIUS IN FEET	LOADED BOOM ANGLE	33-ft	A	46-ft	B	57-ft	C	69-ft	D	81-ft	E	93-ft	F	105-ft
6	76.1	100,000												
9	71.3	80,000												
10	69.1	64,500	75.5	46,600										
12	65.2	58,100	72.9	46,600	77.1	46,600								
15	59.1	50,800	69.0	46,600	74.1	44,600	77.8	41,700						
20	47.7	29,600	61.7	33,300	68.4	34,000	73.4	34,900	76.6	30,700				
25	34.1	17,400	53.6	19,500	62.2	20,300	68.1	20,800	72.4	21,400	75.7	22,000	78.2	20,000
30			44.9	13,000	55.8	13,450	63.1	13,900	68.1	14,400	71.8	14,800	74.8	15,200
35			35.8	9,000	49.8	9,450	58.4	9,800	63.8	10,200	68.0	10,550	71.4	10,800
40			22.3	6,300	42.5	6,750	53.1	7,100	59.8	7,400	64.7	7,700	68.5	8,000
45					33.9	4,850	47.4	5,100	55.4	5,450	60.9	5,700	65.2	5,950
50					22.9	3,400	41.2	3,650	50.7	3,950	57.1	4,200	61.9	4,400
55							34.0	2,600	45.7	2,850	53.1	3,100	58.5	3,300
60							25.2	1,700	40.3	1,950	48.9	2,150	55.0	2,300
65									34.2	1,200	44.4	1,400	51.4	1,500
	0	9,800	0	4,850	0	2,400	0	800						
DEDUCTIONS FOR STOWED JIB (lbs)		1,000		750		600		500		400		350		300
DEDUCTIONS FOR STOWED JIB (lbs)		650		500		400		350		250		200		200

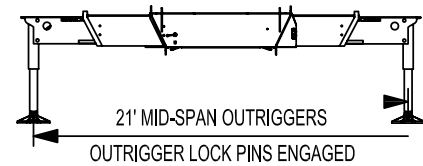

ELLIOTT EQUIPMENT CO. SUPPLIED
LOADLINE EQUIPMENT DEDUCTIONS:
DOWNHAUL WEIGHT225 lbs
ONE SHEAVE BLOCK.....424 lbs
TWO SHEAVE BLOCK.....592 lbs
THREE SHEAVE BLOCK.....639 lbs
FOUR SHEAVE BLOCK.....762 lbs
AUXILIARY SHEAVE.....100 lbs

NOTE:

- Operate jib by radius when main boom is fully extended.
Increase boom angle if necessary to maintain load radius.
- When boom is retracted, operate jib by boom angles.
Do not exceed any rated jib capacities at reduced boom lengths.
- Capacities do not exceed stability based on ISO 4305-1991.
- Load ratings above bold line are structurally limited.
- Personnel handling is allowed only with full span outriggers.
- Boom load ratings are based on loaded boom radius.
Loaded boom angles are given as reference only.

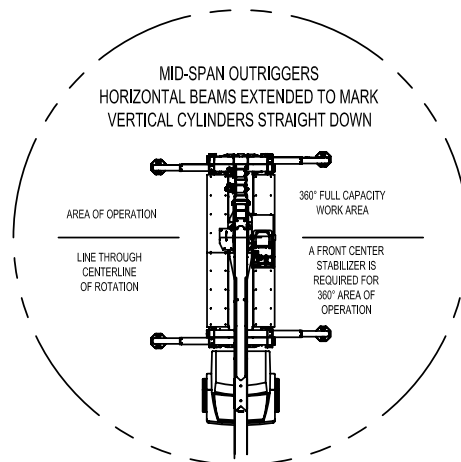

CRANE MEETS ASME B30.5 REQUIREMENTS AT TIME OF MANUFACTURE

DO NOT PAINT OVER ANY LABELS 1141880 080708



Elliott Equipment Company Phone: 402-592-4500
4427 South 76th Circle Fax: 402-592-4553
Omaha, NE 68127 Email: sales@elliottequip.com

Built for You.
www.elliottequip.com

LOAD CHART - MAIN BOOM, RETRACTED OUTRIGGERS



MODEL 5000

105-ft BOOM

MAIN BOOM LOAD RATINGS WITH OUTRIGGERS AT RETRACTED POSITION

RANGE DIAGRAM WITH OUTRIGGERS IN RETRACTED POSITION

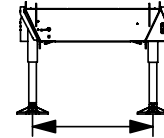
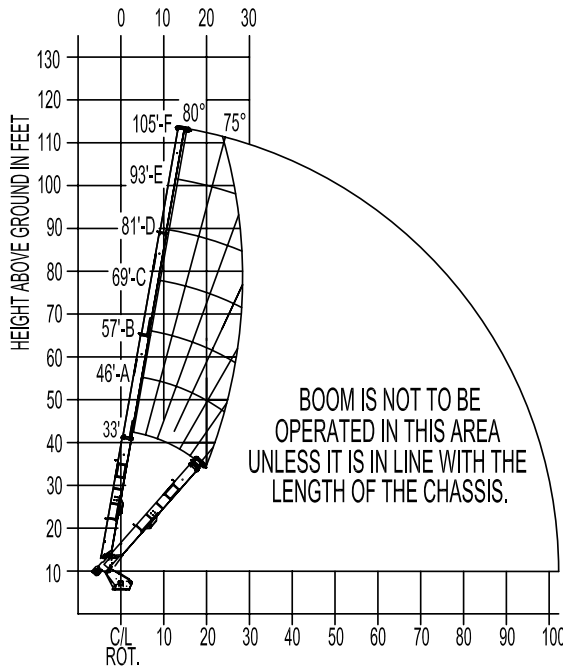

7' RETRACTED OUTRIGGERS
OUTRIGGER LOCK PINS DISENGAGED AND BEAMS
AT FULL HORIZONTAL RETRACT

- ELLIOTT EQUIPMENT CO. SUPPLIED
LOADLINE EQUIPMENT DEDUCTIONS:
- DOWNHAUL WEIGHT225 lbs
 - ONE SHEAVE BLOCK.....424 lbs
 - TWO SHEAVE BLOCK.....592 lbs
 - THREE SHEAVE BLOCK.....639 lbs
 - FOUR SHEAVE BLOCK.....762 lbs
 - AUXILIARY SHEAVE.....100 lbs

LOAD RADIUS FROM CENTERLINE OF ROTATION IN FEET

MAIN BOOM LOAD RATINGS WITH REDUCED SPAN OUTRIGGERS

LOAD RATINGS IN lbs WITH OUTRIGGERS RETRACTED AND STABILIZERS EXTENDED

LOAD RADIUS IN FEET	LOADED BOOM ANGLE	33-ft	46-ft	A	LOADED BOOM ANGLE	B	LOADED BOOM ANGLE	C	LOADED BOOM ANGLE	D	LOADED BOOM ANGLE	E	LOADED BOOM ANGLE	F
9	70.2	18,800												
10	68.2	15,000	74.6	16,600										
12	64.3	10,350	71.8	11,500	75.7	11,900								
15	59.3	6,050	68.3	6,900	72.9	7,150	76.2	7,400						
20	48.6	2,250	61.2	2,950	67.3	3,150	71.6	3,300	74.6	3,500				
25			53.7	850	61.5	1,000	67.0	1,150	70.7	1,300	73.5	1,400	75.7	1,500
DEDUCTIONS FOR STOWED JIB (lbs)		1,000	750	600	500	400	350	300	DEDUCTIONS FOR STOWED EXTENDABLE JIB (lbs)					
DEDUCTIONS FOR STOWED FIXED LENGTH JIB (lbs)		650	500	400	350	250	200	200	DEDUCTIONS FOR STOWED FIXED LENGTH JIB (lbs)					

NO-SPAN OUTRIGGERS
HORIZONTAL BEAMS FULLY RETRACTED
VERTICAL CYLINDERS STRAIGHT DOWN

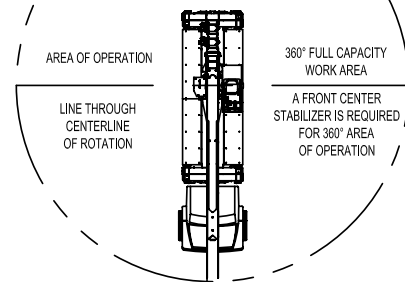

CRANE MEETS ASME B30.5 REQUIREMENTS AT TIME OF MANUFACTURE

DO NOT PAINT OVER ANY LABELS 1141880 080708

RANGE CHART - MAIN BOOM, FULL-SPAN OUTRIGGERS



MODEL 5000 105-ft BOOM

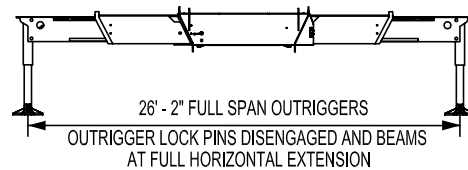
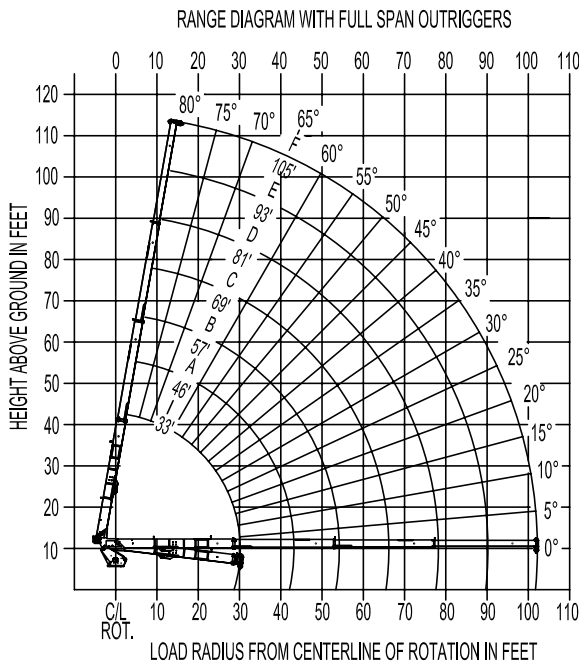

- NOTE:**
1. Operate jib by radius when main boom is fully extended. Increase boom angle if necessary to maintain load radius.
 2. When boom is retracted, operate jib by boom angles. Do not exceed any rated jib capacities at reduced boom lengths.
 3. Capacities do not exceed 85% stability.
 4. Load ratings above bold line are structurally limited.
 5. Personnel handling is allowed only with full span outriggers.
 6. Boom load ratings are based on loaded boom radius. Loaded boom angles are given as reference only.

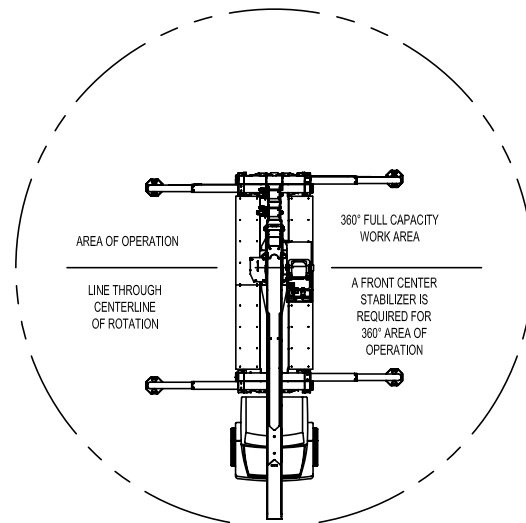

CRANE MEETS ASME B30.5 REQUIREMENTS AT TIME OF MANUFACTURE

DO NOT PAINT OVER ANY LABELS 1141880 080708

RANGE CHART - MAIN BOOM, MID-SPAN OUTRIGGERS



MODEL 5000 105-ft BOOM

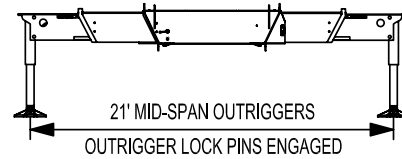

RANGE DIAGRAM WITH OUTRIGGERS IN MID-SPAN POSITION

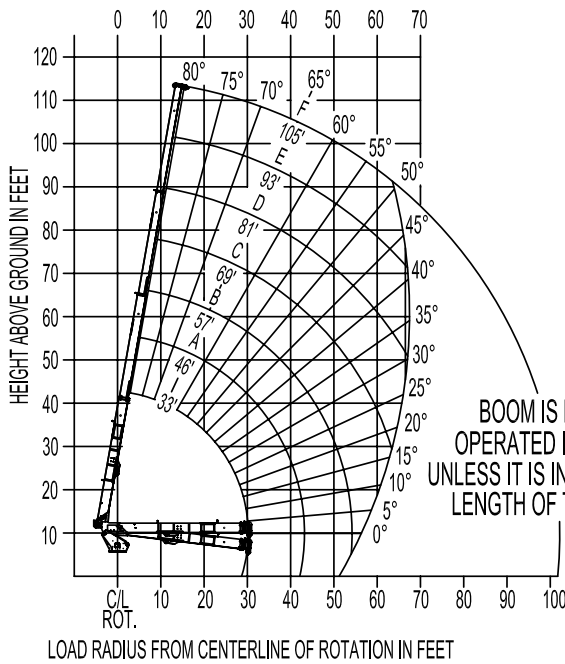

NOTE:

1. Operate jib by radius when main boom is fully extended. Increase boom angle if necessary to maintain load radius.
2. When boom is retracted, operate jib by boom angles. Do not exceed any rated jib capacities at reduced boom lengths.
3. Capacities do not exceed stability based on ISO 4305-1991.
4. Load ratings above bold line are structurally limited.
5. Personnel handling is allowed only with full span outriggers.
6. Boom load ratings are based on loaded boom radius. Loaded boom angles are given as reference only.

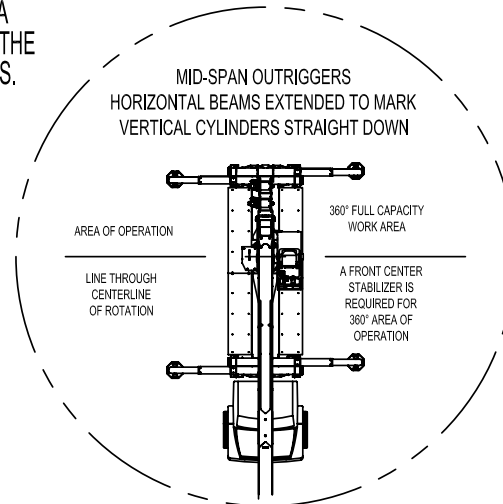

CRANE MEETS ASME B30.5 REQUIREMENTS AT TIME OF MANUFACTURE

DO NOT PAINT OVER ANY LABELS

1141880 080708

LOAD CHART - TELESCOPIC JIB, FULL-SPAN OUTRIGGERS



MODEL 5000 105-ft BOOM

JIB LOAD RATINGS WITH FULLY EXTENDED OUTRIGGERS

LOAD RADIUS IN FEET	32' SINGLE SECTION JIB		32-49 ft EXTENDABLE JIB			
	LOADED BOOM ANGLE	32-ft JIB 360°	LOADED BOOM ANGLE	32-ft JIB 360°	LOADED BOOM ANGLE	49-ft JIB 360°
35	77.6	6,400	77.4	6,050		
40	75.4	5,850	75.2	5,500	77.6	5,100
45	73.2	5,400	73.0	5,150	75.8	4,800
50	71.1	5,200	70.8	4,850	73.9	4,500
55	68.8	4,900	68.5	4,550	72.1	4,250
60	66.5	4,650	66.2	4,300	70.1	4,000
65	64.1	4,350	63.8	4,000	68.1	3,750
70	61.6	4,050	61.3	3,700	66.0	3,450
75	59.0	3,750	58.7	3,400	63.8	3,200
80	56.1	3,250	56.1	3,250	61.7	3,000
85	53.4	3,150	53.2	2,900	59.4	2,750
90	50.6	2,950	50.2	2,600	57.0	2,500
95	47.2	2,400	46.8	2,050	54.5	2,250
100	43.6	1,900	43.2	1,550	52.0	2,000
105	39.8	1,450	39.4	1,100	49.3	1,750
110	35.7	1,050	35.3	700	46.4	1,500
115	31.4	850	31.0	500	43.4	1,250
120					40.2	950
125					36.6	600

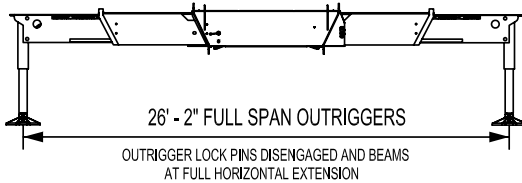
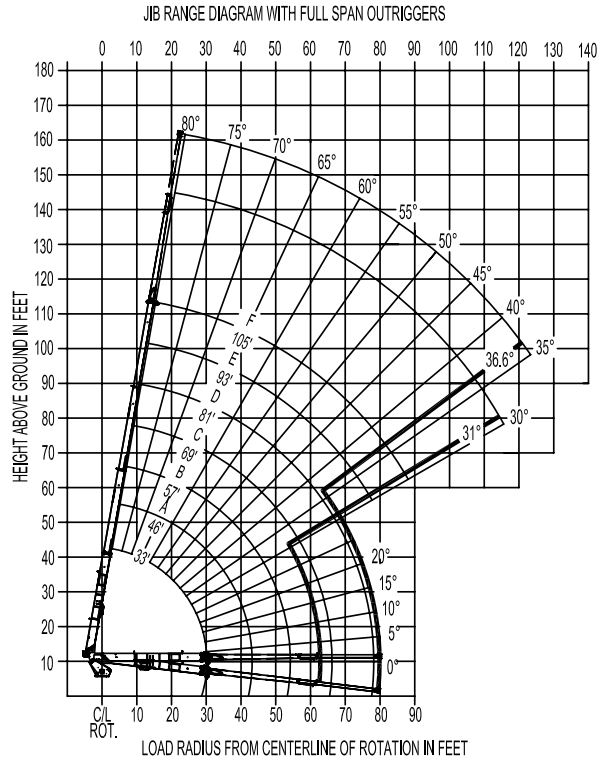

- NOTE:
1. Operate jib by radius when main boom is fully extended. Increase boom angle if necessary to maintain load radius.
 2. When boom is retracted, operate jib by boom angles. Do not exceed any rated jib capacities at reduced boom lengths.
 3. Capacities do not exceed 85% stability.
 4. Load ratings above bold line are structurally limited.
 5. Personnel handling is allowed only with full span outriggers.
 6. Boom load ratings are based on loaded boom radius. Loaded boom angles are given as reference only.

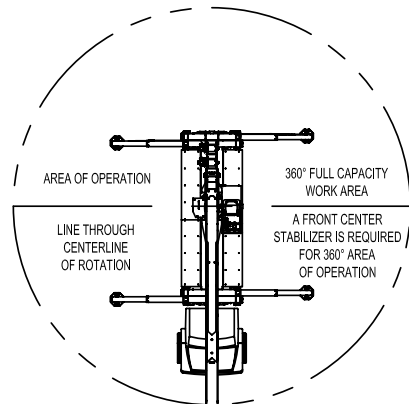

CRANE MEETS ASME B30.5 REQUIREMENTS AT TIME OF MANUFACTURE

DO NOT PAINT OVER ANY LABELS

1141880 080708

LOAD CHART - TELESCOPIC JIB, MID-SPAN OUTRIGGERS



MODEL 5000 105-ft BOOM

JIB LOAD RATINGS WITH MID-SPAN OUTRIGGERS

32' SINGLE SECTION JIB			32-49 ft EXTENDABLE JIB			
LOAD RADIUS IN FEET	LOADED BOOM ANGLE	32-ft JIB 360°	LOADED BOOM ANGLE	32-ft JIB 360°	LOADED BOOM ANGLE	49-ft JIB 360°
35	77.6	6,400	77.4	6,050		
40	75.4	5,850	75.2	5,500	77.6	5,100
45	73.2	5,400	73.0	5,150	75.8	4,800
50	71.1	5,200	70.8	4,850	73.9	4,500
55	68.8	4,900	68.5	4,550	72.1	4,250
60	66.5	4,300	66.0	4,050	70.1	4,000
65	64.1	3,350	63.1	3,100	68.1	3,750
70	61.6	2,550	60.1	2,300	65.6	3,100
75	59.0	1,850	57.1	1,600	63.0	2,350
80	56.1	1,250	54.1	1,000	60.5	1,800
85	53.4	750	51.0	500	57.9	1,250
90					55.3	800

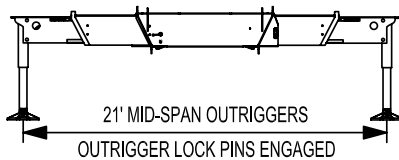
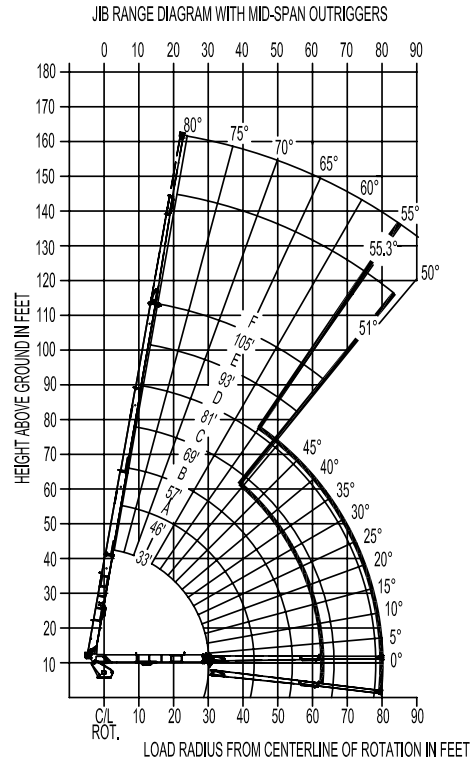

- NOTE:**
1. Operate jib by radius when main boom is fully extended. Increase boom angle if necessary to maintain load radius.
 2. When boom is retracted, operate jib by boom angles. Do not exceed any rated jib capacities at reduced boom lengths.
 3. Capacities do not exceed stability based on ISO 4305-1991.
 4. Load ratings above bold line are structurally limited.
 5. Personnel handling is allowed only with full span outriggers.
 6. Boom load ratings are based on loaded boom radius. Loaded boom angles are given as reference only.

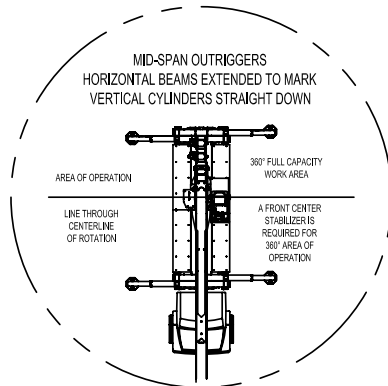

CRANE MEETS ASME B30.5 REQUIREMENTS AT TIME OF MANUFACTURE

DO NOT PAINT OVER ANY LABELS

1141880 080708

MAIN BOOM WINCH DATA



MODEL 5000

105-ft BOOM

PARTS OF LINE

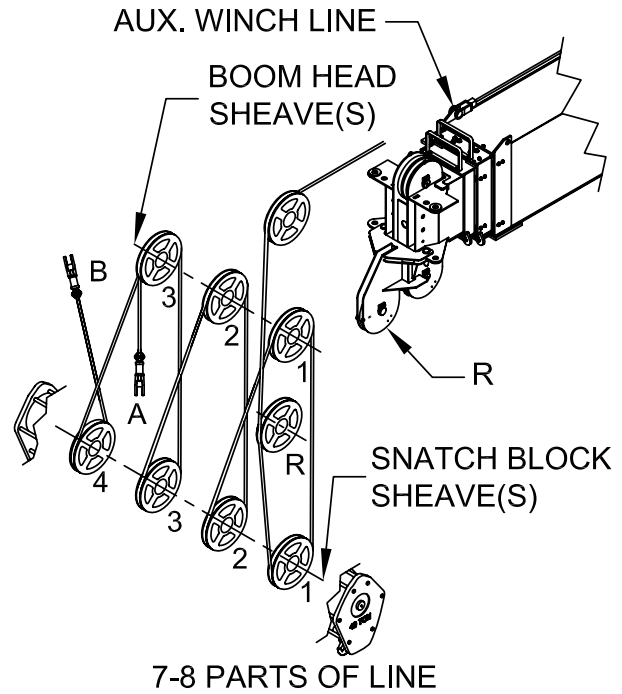
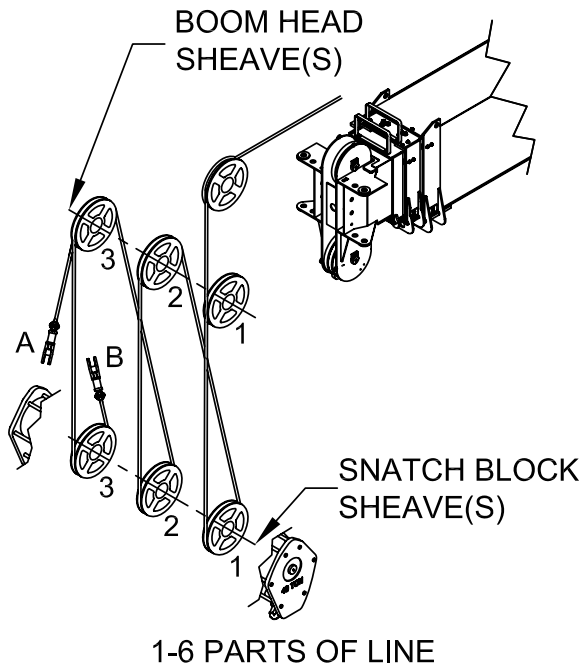

NOTICE:

- DO NOT DEADHEAD LINE BLOCK AGAINST BOOM TIP WHEN EXTENDING BOOM.
- KEEP AT LEAST 5 WRAPS OF LOADLINE ON THE WINCH DRUM AT ALL TIMES.
- USE ONLY 5/8" DIAMETER WIRE ROPE, AS SPECIFIED, WITH THE PROPER BREAKING STRENGTH LISTED.
- ANTI-TWO-BLOCK SYSTEM MUST BE IN GOOD OPERATING CONDITION BEFORE OPERATING CRANE. SEE OPERATION & SAFETY MANUAL.

PARTS OF LINE	SHEAVE(S) ON BOOM HEAD	SHEAVE(S) ON SNATCH BLOCK	5/8" - SPIN RESISTANT (5:1 S.F.) 50,000-lbs. BREAKING STRENGTH	5/8" - 6X36 IWRC (3.5:1 S.F.) 45,400-lbs. BREAKING STRENGTH
1	1	A	10,000 lbs	12,500 lbs
2	1B	1	20,000 lbs	25,000 lbs
3	12	1A	30,000 lbs	37,500 lbs
4	12B	12	40,000 lbs	50,000 lbs
5	123	12A	50,000 lbs	62,500 lbs
6	123B	123	60,000 lbs	75,000 lbs
7	R123	123A	70,000 lbs	87,500 lbs
8	R123B	1234	80,000 lbs	100,000 lbs

A-DEAD END FOR ODD PARTS OF LINE
 B-DEAD END FOR EVEN PARTS OF LINE
 R-ROOSTER SHEAVE REQUIRED WHEN USING 7 AND 8 PARTS OF LINE

CRANE MEETS ASME B30.5 REQUIREMENTS AT TIME OF MANUFACTURE

DO NOT PAINT OVER ANY LABELS

1141880 080708



Elliott Equipment Company
 4427 South 76th Circle
 Omaha, NE 68127
 Phone: 402-592-4500
 Fax: 402-592-4553
 Email: sales@elliottequip.com

Built for You.
www.elliottequip.com

TRUCK CHASSIS SPECIFICATIONS

	50105R BoomTruck
Wheelbase (WB)	288" / 731 cm
Cab to Tandem (CT)	198" / 503 cm
Cab to End of Frame (EOF)	345" / 876 cm
Frame Section Modulus	30.0 in ³ -110,000 psi / 758,428 kPa
Front Axle Gross Weight Rating	20,000 lb / 9,072 kg
Rear Axle Gross Weight Rating	58,000 lb / 26,308 kg
Integral Front Frame Rails	Required

Chassis data is minimum general requirements-not for engineering.
 Actual dimensions and truck data will depend on truck selection and axle configuration.
 *Minimum chassis weight is required to meet 85% stability requirements.

OPTIONS



Radio Remote Control

Interference protected radio remotes let you get closer to your work and have full control over your machine. Optional LMI display is available.

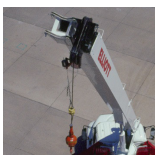

Pin-On Jib Attachments

One piece & two piece telescoping or fixed jibs that stow on the side of the boom for easy placement while on the worksite.



Air Conditioning in Crane Cab

Work all day in comfort with an high efficiency air conditioning system mounted on the rear of the crane control cab.



Dual Winch System & Drum Indicators

Take advantage of Elliott's auxiliary dual 10,000 lb single line pull winch package with optional winch drum rotation indicators.



Tool Boxes

Optional tool boxes and bed storage can accommodate any storage need for tools, work materials and more.

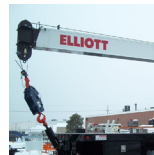

Hook Block for Multi-Part Line

Elliott can include a hook block device for up to 8 parts of line to improve lifting capabilities and allow you to maximize your use of the crane.



2-Man Yoke Work Platform

Elliott's 600 lb capacity 2-man platform features a hydraulic yoke lifting system for easy attachment to the boom tip. Fully OSHA compliant and heavy duty.



Body Mounted Hose Reels and Circuits

Let us work with you to customize your tool compatibility by adding hose reels or hydraulic circuits to the crane bed.